

Air Circuit Breaker

NXA series air circuit breaker P-001

Overview P-003

Product selection P-005

Functions and features

Technical parameters	P-009
Intelligent controller	P-011
Protection feature	P-015
Measurement precision of the intelligent controller	P-017
Accessories	P-019
Capacity derating and power loss	P-023
Dimension of busbar	P-026
Selective protection between NM8 and NXA	P-027

Installation and wiring

Dimensions and installation	P-029
Secondary circuit wiring	P-051

Annex

I Configuration	P-056
II Selection table	P-057
III Earth fault protection	P-058
IV Source-changeover controller	P-061

Structural features of the circuit breaker

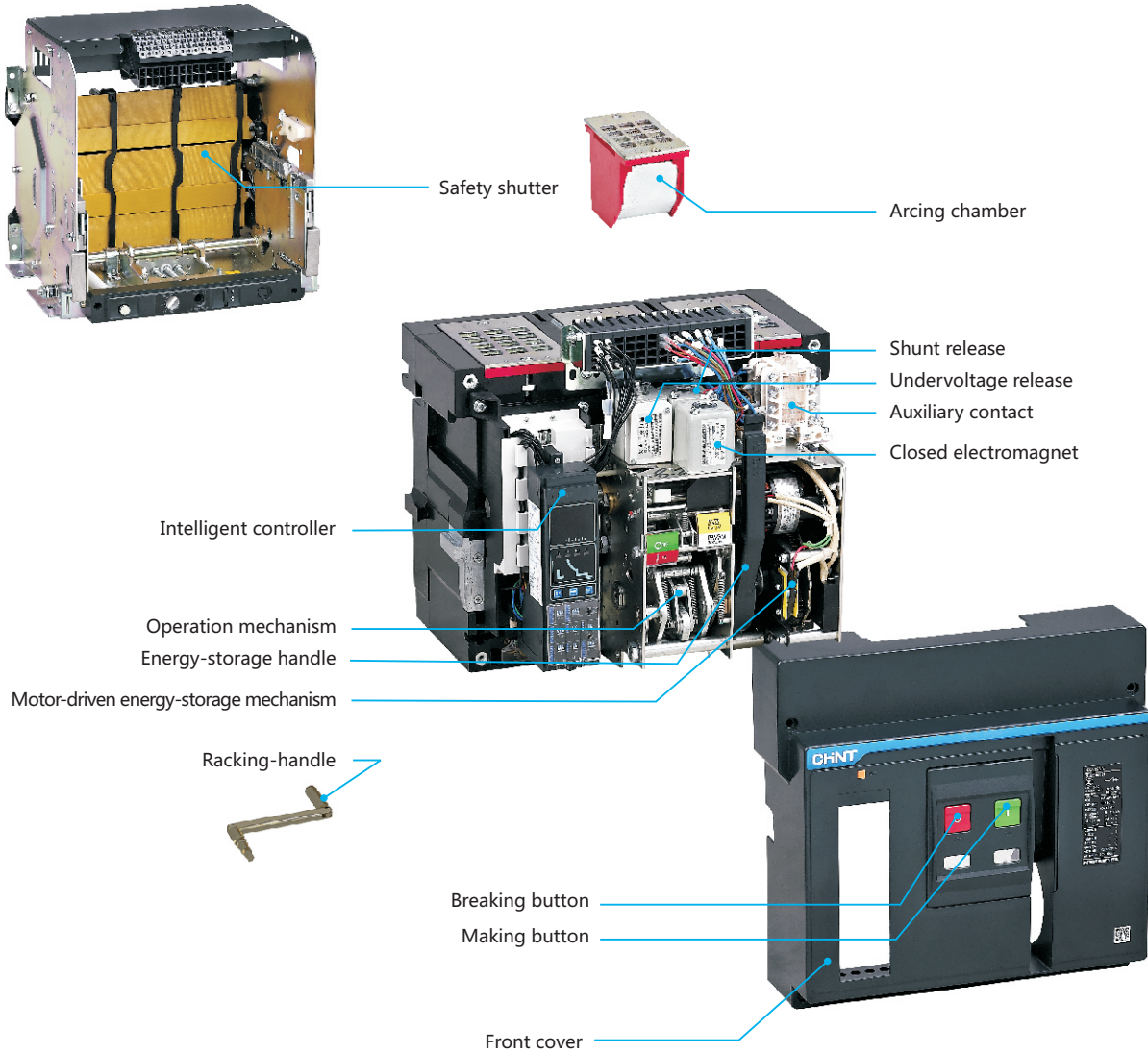

Circuit breaker description

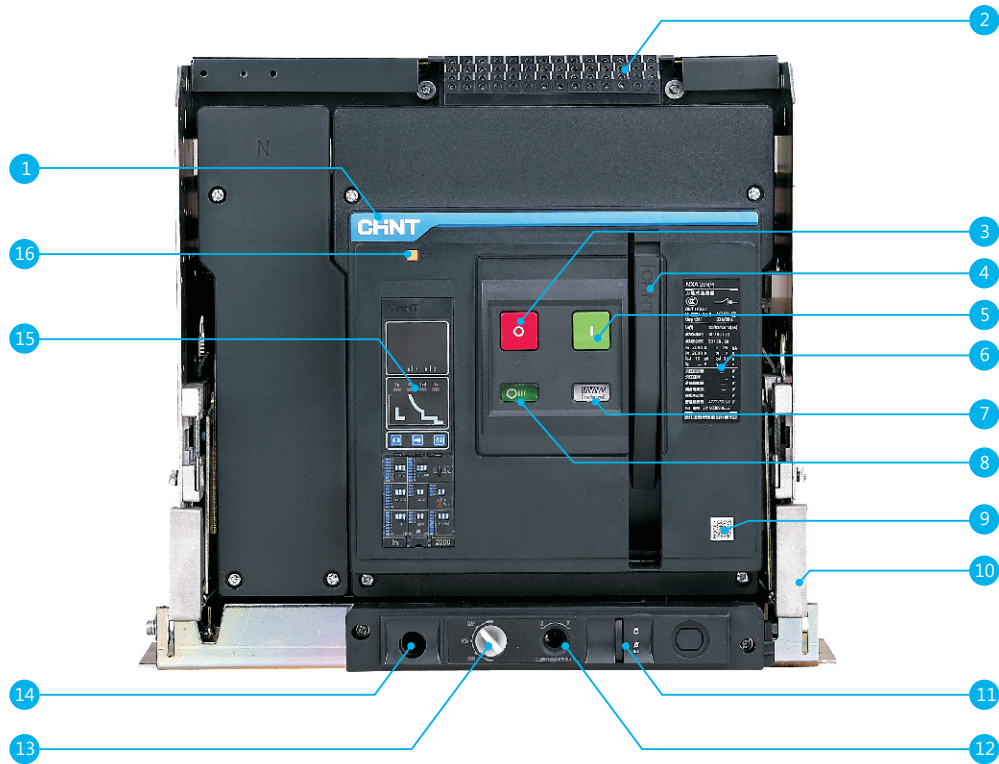

- | | |
|------------------------------------|---|
| 1 Trademark | 9 QR code |
| 2 Secondary wiring terminal | 10 Extraction draw plate (only applicable to draw-out type) |
| 3 Breaking button | 11 "Disconnected" position locking (only applicable to draw-out type) |
| 4 Energy-storage handle | 12 Racking-handle entry (only applicable to draw-out type) |
| 5 Making button | 13 Position indication (only applicable to draw-out type) |
| 6 Nameplate | 14 Racking-handle storage (only applicable to draw-out type) |
| 7 Energy-storage/release indicator | 15 Intelligent controller |
| 8 Breaking/making indicator | 16 Fault-breaking indicator reset button |



Circuit breaker

- Frame size (A): 1600, 2000, 3200, 4000, 6300
- Breaking capacity: N,S,H
- Rated operational voltage Ue (VAC): 380/400/415, 440/525/690
- Number of poles: 3P, 4P
- Installation method: draw-out type, fixed type



Operation conditions and environment adaptability

- Operation temperature:
 - The electrical and mechanical characteristics are applicable to the ambient temperature of -5°C-+40°C. NXA can also operate in the ambient temperature of -45°C-+70°C (M type, A type), -20°C-+70°C (P type, H type, CD-1), the derating factor is seen in P23-24.
- Storage conditions: apply to -45°C~+70°C
- NXA can resist the following electromagnetic interference
 - Overvoltage generated by electromagnetic interference
 - Overvoltage caused by environment interference or a power distributing system
 - Electrostatic discharge of radio waves (radio, intercom, radar and the like)
- NXA has successfully passed the test for electromagnetic compatibility specified according to the following standards (EMC) IEC/EN 60947-2 Annex F
 - The test can guarantee no false tripping and no interference on tripping time
- Protection grade:
 - Front IP 20, other side IP 00

Connection

- Rear connection
 - Horizontal connection, vertical connection
- Optional accessories
 - Interphase barrier

Lock

- Padlocks of "Making" and "Breaking" push button
- Position padlock (for locking the circuit breaker at disconnected position)
- Chassis padlock
- Door interlock: the circuit breaker is arranged at the connected or test part so as to prohibit to open the door

Indication contact

- Standard contact
 - Making and breaking indication contacts
 - Fault tripping indication contact
- Optional accessories
 - Position indication contact
 - Spring charged indication contact

Drawout type breaker

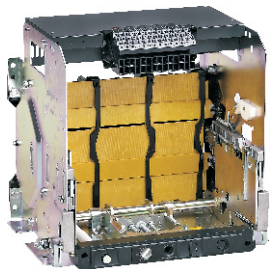

Drawer seat

+



Body

=



Drawout type breaker

Fixed type breaker



NXA16



NXA20 - NXA40

Note: NXA63 fixed type is seen in P45

Accessories



Interphased partition

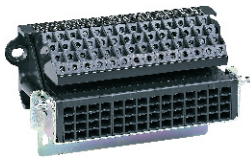

Secondary wiring terminal-drawout type

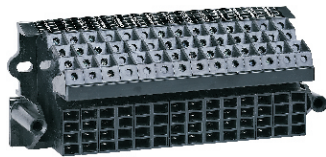

Secondary wiring terminal-fixed type



N pole CT



Counter



PSU-1



NXA series air circuit breaker

Frame size	Rated current Breaking capacity	400	630	800	1000	1250	1600	2000	2500	3200	3600	4000	5000	6300
		1600A	N	■	■	■	■	■	■					
	S	■	■	■	■	■	■							
	H	■	■	■	■	■	■							
2000A	N		■	■	■	■	■	■						
	S		■	■	■	■	■	■						
	H		■	■	■	■	■	■						
3200A	N						■	■	■	■				
	S						■	■	■	■				
	H						■	■	■	■				
4000A	N									■	■	■		
	S									■	■	■		
	H									■	■	■		
6300A	H											■	■	■

Model definition and description

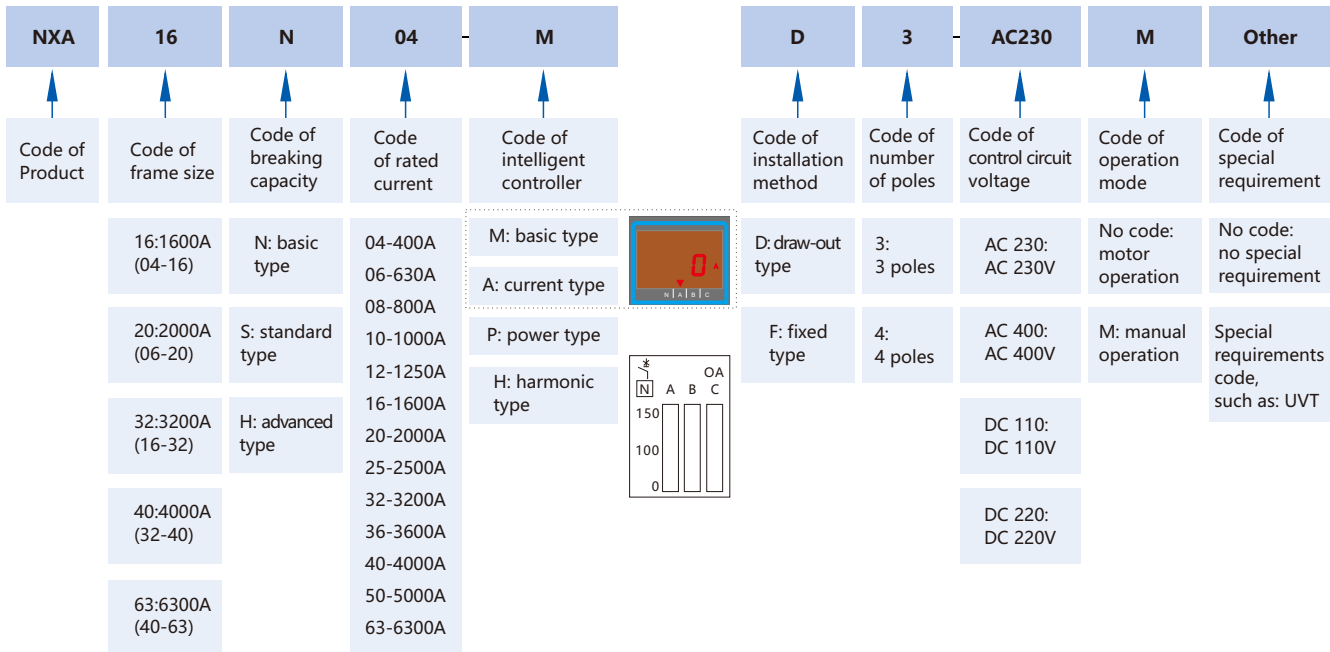

Note: ¹⁾ Intelligent controller PT/HT type. The basic functions are the same with P/H type. T refers to the internal temperature measurement function.
²⁾ Manual operation does not contain motor-driven mechanism, closing electromagnet and shunt release. Motor operation contains all standard accessories of remote operation.
³⁾ Auxiliary working voltage of the intelligent controller: corresponding power modules is required if DC220V or DC110V is selected.
⁴⁾ NXA16N10-AD3-AC230: frame size is 1600A, N type breaking capacity, rated current is 1000A, A type intelligent controller, draw-out type and 3 poles, control voltage is AC 230V motor operation.

Model definition and description-intelligent controller

NXA	16	TU	M	-	04	-	3	-	AC230
Code of product	Code of frame size	Intelligent controller	Code of intelligent controller		Code of rated current		Code of number of poles		Code of auxiliary power supply
	16:1600A (04-16)		M: basic type		04-400A; 06-630A		3: 3 poles		AC 230: AC 230V
	20:2000A (06-20)		A: current type		08-800A; 10-1000A		4: 4 poles		AC 400: AC 400V
	32:3200A (16-32)		P: power type		12-1250A; 16-1600A				DC 110: DC 110V
	40:4000A (32-40)		H: harmonic type		20-2000A; 25-2500A				DC 220: DC 220V
	63:6300A (40-63)				32-3200A; 36-3600A				
					40-4000A; 50-5000A				
					63-6300A				

Model definition and description-accessories

NXA	16	-	CC	-	230VAC
Code of product	Frame size		Code of accessories		Code of rated voltage
	16:1600A		CC: Closed electromagnet		230VAC: AC230V
	20:2000A		ST: Shunt tripper		400VAC: AC400V
	32:3200A		MO: Motor		110VDC: DC110V
	40:4000A		UVT: Undervoltage tripper		220VDC: DC220V
	63:6300A		ASUVT:Self-priming undervoltage tripper		Rated voltage+delay time (1s, 3s, 5s, 7s)
	20/40:2000A-4000A		UVTD:UVT delay unit		
	20/32:2000A-3200A		ASUVTD: ASUVT delay unit		
	20/63:2000A-6300A				



Model definition and description-accessories

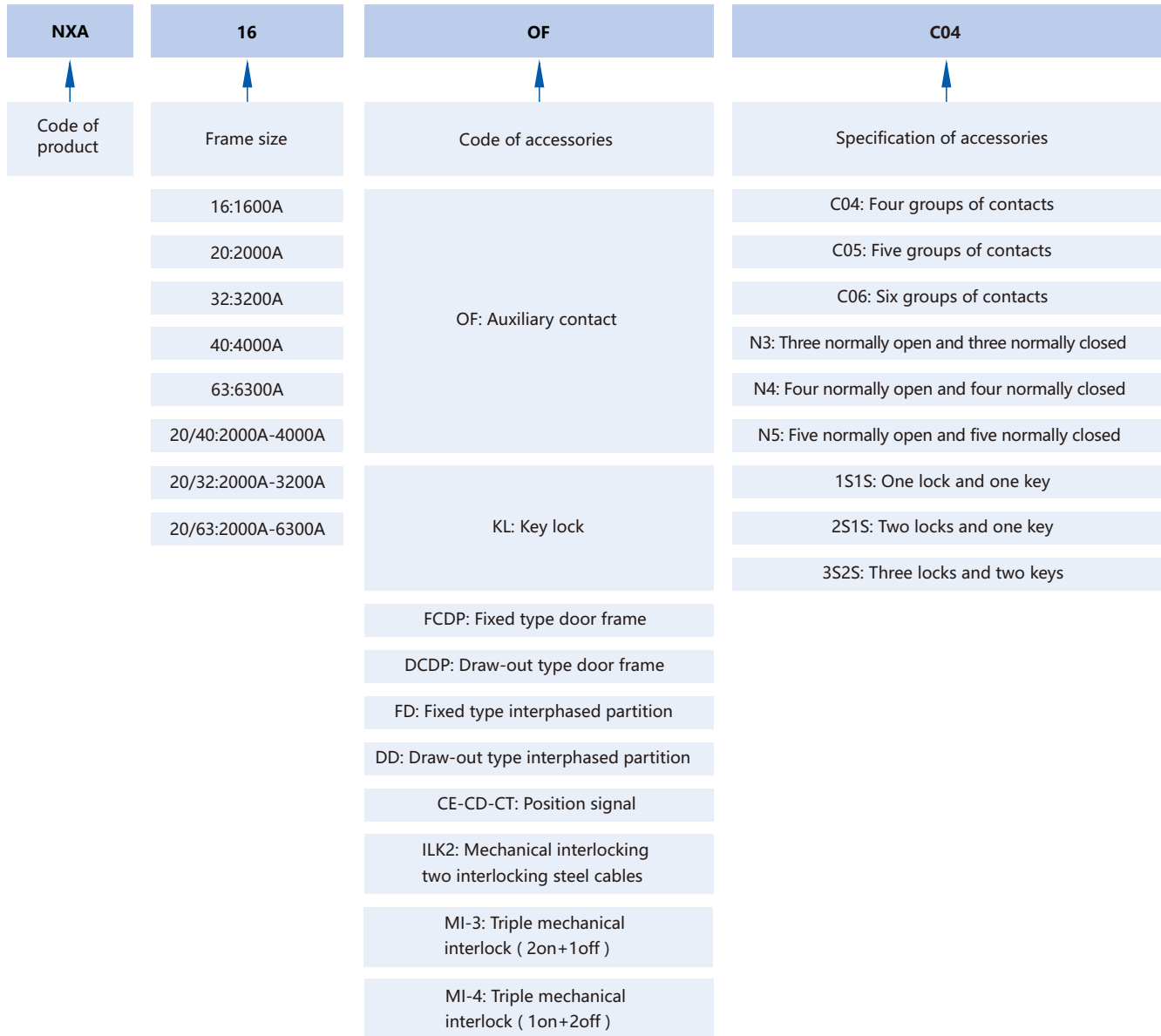

Technical parameters

Features

Number of poles	3/4 6300A only 3P	
Rated operational voltage Ue (V)	AC 380/400/415 , AC 440/525/690	
Rated insulation voltage Ui (V)	1000	
Rated impulse withstand voltage Uimp (kV)	12	
Rated frequency (Hz)	50/60	
Flashover distance (mm)	0	
Applicable to isolation	IEC/EN 60947-2	Applicable
Pollution grade	IEC 60664-1	N:3

Frame size			1600A					
Rated current (A)			400	630	800	1000	1250	1600
Rated current of the fourth pole (A)			400	630	800	1000	1250	1600
Type of the circuit breaker			N	S	H			
Rated ultimate short circuit breaking capacity (kA rms) VAC 50/60Hz	Icu	380/400/415V	50	42	50			
		440/525/690V	30	36	36			
Rated service short circuit breaking capacity (kA rms) VAC 50/60Hz	Ics	380/400/415V	42	42	50			
		440/525/690V	30	36	36			
Utilization category			B					
Rated short-time withstand current (kA rms) VAC 50/60Hz	Icw 1s	380/400/415V	42	42	42			
		440/525/690V	30	36	36			
	Icw 3s	380/400/415V	20	25	25			
		440/525/690V	-	-	-			
Closed capacity (kA peak) VAC 50/60Hz	Icm	380/400/415V	105	88.2	105			
		440/525/690V	63	75.6	75.6			
Making current tripping protection function (MCR kA rms)			10	16	16			
Breaking time (ms)			32					
Closing time (ms)			70					
Installation, connection and service life								
Service life C/O cycle	Mechanical	Without maintenance	15000					
	Electrical	Without maintenance	8000					
Connection	Horizontal		▪					
Size (width × depth × height)	Fixed type	3P	254×243.5×318.5					
		4P	324×243.5×318.5					
	Draw-out type	3P	308×331.5×351					
		4P	378×331.5×351					

2000A						3200A				4000A			6300A				
630	800	1000	1250	1600	2000	1600	2000	2500	3200	3200	3600	4000	4000	5000	6300		
630	800	1000	1250	1600	2000	1600	2000	2500	3200	3200	3600	4000	2000	2500	-		
N	S	H				N	S	H				N	S	H			
80	65	80				80	80	100				80	85	100	120		
50	55	55				65	70	70				65	75	75	85		
50	65	65				80	80	85				80	85	85	120		
50	55	55				65	70	70				65	75	75	85		
B						B						B			B		
50	65	65				65	80	85				65	85	85	100		
50	55	55				65	70	70				65	75	75	75		
37	42	42				37	50	50				37	50	50	-		
-	-	-				-	-	-				-	-	-	-		
176	143	176				176	176	220				176	187	220	264		
105	121	121				143	154	154				143	165	165	187		
16	16	16				26	26	26				26	26	26	26		
32						32						32					
70						70						70					
15000						10000				10000			2000				
8000						7000				3000			500				
▪						▪				▪			▪				
374×344×400						439×373.5×400				550×337.5×400			897×435.5×399				
469×344×400						554×373.5×400				700×337.5×400			897×435.5×399				
403×430×438.5						463×499.5×438.5				569×416×438.5			923×500×435.5				
498×430×438.5						578×499.5×438.5				719×416×438.5			923×500×435.5				

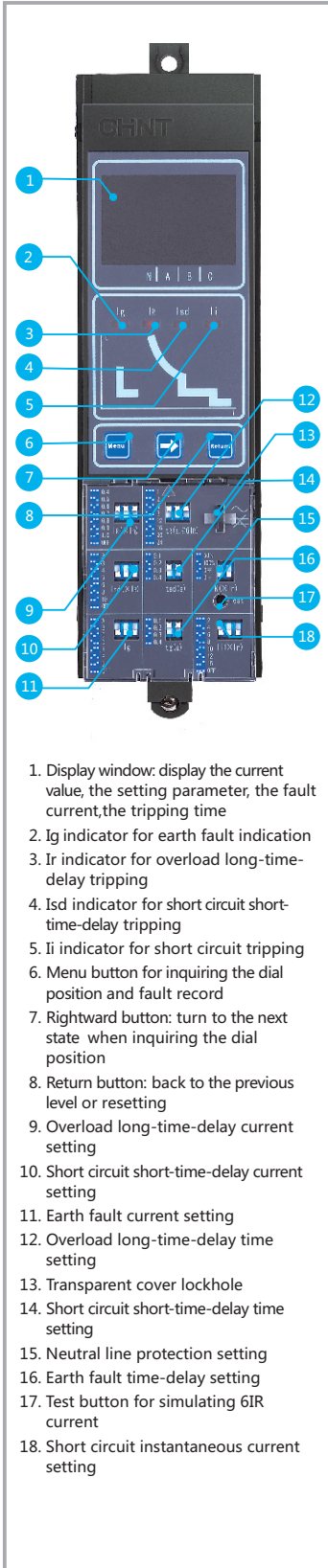

Intelligent controller

M type intelligent controller (Basic type)

Protection

All the protective threshold and time delay are set by a dial switch

- Overload protection
 - True RMS long-time-delay protection
 - Thermal memory: heat accumulation before and after tripping
- Short circuit protection
 - Short-time delay (RMS) and instantaneous protection
 - Optional four steps time-delay setting
- Earth fault protection
 - Optional four steps time-delay setting
- Neutral line overcurrent protection (4P)
 - The neutral protective threshold can be adjusted to 50%, 100% and OFF
- Test function
 - Simulating 6Ir test current for test tripping
- Tripping record function
- Ampere meter
 - Measure the real and effective value (RMS) of current with the precision of 2% for 40% to 150% in setting

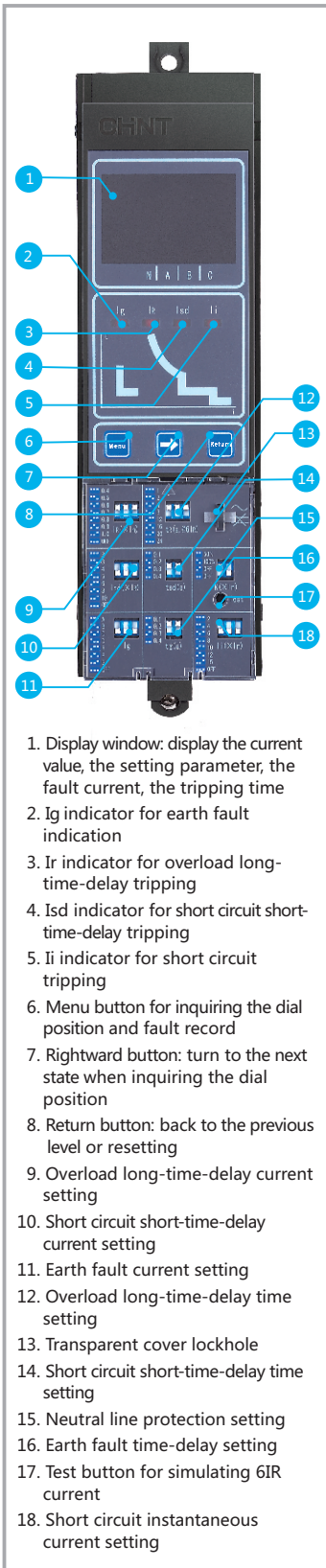

A type intelligent controller (Current type)

Protection

All the protective threshold and time delay are set by a dial switch

- Overload protection
 - True RMS long-time-delay protection
 - Thermal memory: heat accumulation before and after tripping
- Short circuit protection
 - Short-time delay (RMS) and instantaneous protection
 - Optional four steps time-delay setting
- Earth fault protection
 - Optional four steps time-delay setting
- Neutral line overcurrent protection (4P)
 - The neutral protective threshold can be adjusted to 50%, 100% and OFF
- Unbalanced current protection
 - Protecting phase failure or three phase unbalance
- Test function
 - Simulating 6Ir test current for test tripping
- Tripping record function
- Ampere meter
 - Measure the real and effective value (RMS) of current with the precision of 2% for 40% to 150% in setting



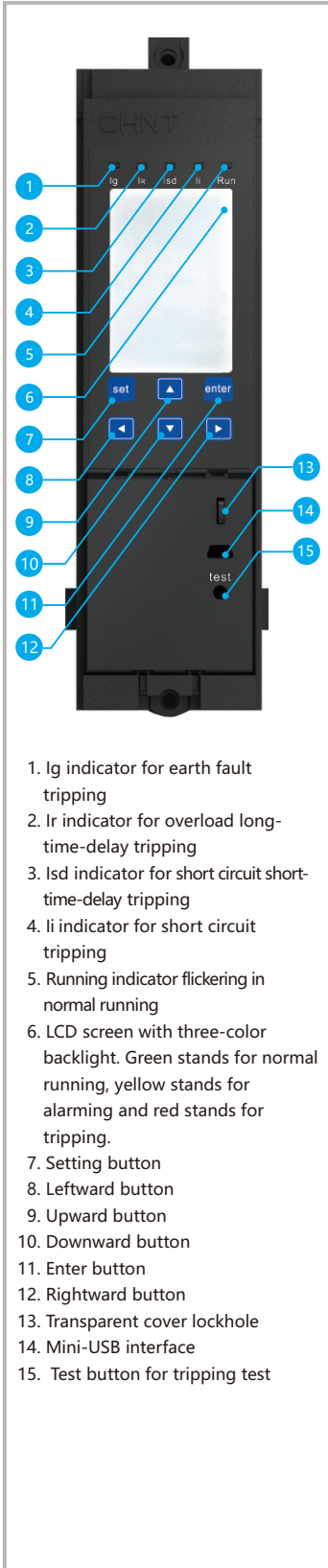

P type intelligent controller (Power type)

Protection

Setting all protective threshold values and time-delay by button
 The setting values can be displayed on LCD display window

- Protection functions of all A type control units are included
- Earth current protection function (Optional)
 External transformer are configured
- Advanced protection function
 - Unbalanced voltage protection
 - Overvoltage and undervoltage protection
 - Overfrequency and underfrequency protection
 - Phase sequence protection
 - Reverse power protection function
 - Required value protection function

The required value of the real and effective value of each current is calculated within a measurement window. When the required value is off limit, the protection action is carried out. The setting of a sliding time window is in the menu of "setting of a measurement meter".

 - A-phase maximal required current value,
 - B-phase maximal required current value,
 - C-phase maximal required current value,
 - N-phase maximal required current value are respectively set for each circumstance of the required value protection without being affected by the setting of the neutral line protection.
- Extended function
 - Self-diagnosis by the intelligent controller
 - Operation times/fault tripping/alarming/deflection recording function provides the latest ten times of recording
 - Main contact abrasion display function for evaluating the contact abrasion degree according to mechanical life, electrical services and breaking capacities of different frames.
 - Internal clock function
 - A Mini-USB interface is connected with a PC to achieve the functions of protection setting, fault record downloading, whole power quantity detection and parameter reading of a circuit breaker.
 - "test" push button
- Electric energy meter
 - Current measurement
 - Voltage measurement
 - Frequency measurement
 - Required value measurement
 - Power (active power, reactive power and apparent) measurement
 - Electric energy (active power, reactive power and apparent) measurement
 - Power factor measurement
- LCD three-color backlight
 Green stands for normal running, yellow stands for alarming and red stands for tripping.

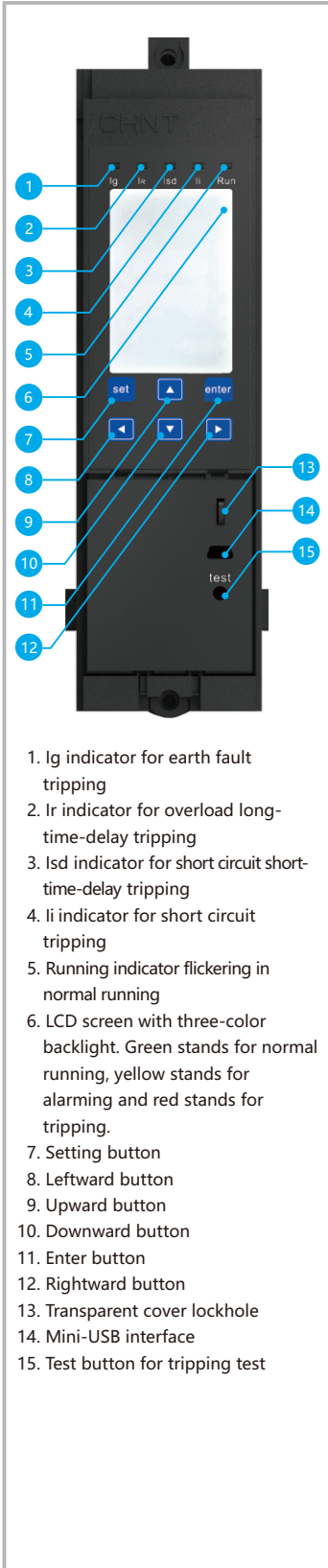

H type intelligent controller (Harmonic wave type)

Protection

Setting all protective threshold values and time-delay by button

Besides the protective extended function of all P type control units, H type control unit also comprises:

- Load monitoring function
- Zone selective interlock (ZSI) (Optional)
- Communication function
 - Modbus-RTU communication protocol
- Input/output function
 - 2DI+2DO or 4DO
 - DI signal: AC230V (Standard configuration, and others can be selected); DC110V
 - DO needs to be configured with a power supply module (24VDC output) and a relay module.
- Harmonic analysis function
 - Measurement of the fundamental wave current, the fundamental wave line voltage, the fundamental wave phase voltage, the fundamental wave power and each 3-31 odd harmonic wave current percentage (HRIh), the harmonic voltage percentage (HRUh), the total harmonic wave current distortion rate (THDi, thdi) and the total harmonic wave voltage distortion rate (THDu, thdu).
 - The harmonic wave percentage(HR) refers to the ratio of root-mean-square value of the Nth harmonic wave component contained in periodic alternative current quantity to the root-mean-square value of the fundamental wave component, and is expressed in percentage.



Protection features

The protection features of the intelligent controller comprise inverse time characteristic and constant time characteristic. When the fault current exceeds the set value of the inverse time limit, the controller performs constant time protection.

The inverse time limit corresponds to the feature curve I^2t .

Overload long-time-delay protection feature

Overload long-time-delay protection action threshold value

$<1.05I_r$: $>2h$, no action

$\geq 1.3I_r$: $<1h$, action

I_r current setting value range: $0.4I_n, 0.5 I_n, 0.6 I_n, 0.7 I_n, 0.8 I_n, 0.9 I_n, 1.0 I_n$ +OFF (M/A); $0.4I_n\sim 1.0I_n$ +OFF(P/H)

Inverse time limit action feature: I^2t , wherein $t=(6/N)^2 \times t_r$

Setting Multiple of Current	Action Time							
1.5I _r	16	32	64	128	192	256	320	384
2I _r	9	18	36	72	108	144	180	216
6I _r	1	2	4	8	12	16	20	24

Note: N --- the multiple I/I_r obtained by dividing failure current by set current

t --- time delay action of the failure action

t_r --- long-time-delay set value

Allowed error of the action time $\pm 15\%$

Conventional factory tuning: $I_r=1.0I_n$

$t_r=2s@6I_r$

Short circuit short-time-delay protection feature

Short circuit short-time-delay protection action threshold value

$<0.85I_{sd}$: no action

$>1.15I_{sd}$: action

I_{sd} current set value range: 2I_r, 3I_r, 4I_r, 5I_r, 6I_r, 8I_r, 10I_r +OFF (max 50kA, M/A); $2I_r\sim 10I_r$ +OFF(max 50kA, P/H)

Current	Action time		Remark
$I_{sd} < 1 \leq 10I_r$	Inverse time limit	Action feature $I^2t = (10I_r)^2 t_{sd}$	P, H
		Setting time s 0.1, 0.2, 0.3, 0.4	
$I \geq 1.1I_{sd}$	Constant time limit	Setting time s 0.1, 0.2, 0.3, 0.4	M, A, P, H
		Minimum s 0.06, 0.16, 0.255, 0.34	
	Maximum s 0.14, 0.24, 0.345, 0.46		
	Return time	0.05, 0.14, 0.25, 0.33	

Note: I_{sd} ---short-time-delay current set value

I --- failure current value

I_r --- long-time-delay set value

t --- failure action time-delay time

t_{sd} ---short-time-delay inverse time limit set value

Permissible error of action time $\pm 15\%$

Conventional factory tuning: $I_{sd}=8I_r(I_r < 6250A)$

$I_{sd}=50kA(I_r \geq 6250A)$

$t_{sd}=0.4s$



Short circuit instantaneous protection features

Short circuit instantaneous protection action threshold value

< 0.85I_i: no action

> 1.15I_i: action

The current setting value of instantaneous action: 2I_n, 4I_n, 6I_n, 8I_n, 10I_n, 12I_n, 15I_n+OFF(NXA40 max50kA, NXA63 max63kA, M/A);
2I_n~15I_n+OFF(NXA40 max 50kA, NXA63 max63kA P/H)

Note: action time ≤ 50ms

Conventional factory tuning: I_i = 12I_n (I_n = 400A ~ 5000A)
I_i = 63kA (I_n = 6300A)

Earth fault protection action features

Earth fault protection action threshold value

< 0.9I_g: no action

> 1.1I_g: action

M/A

Current setting value	A	B	C	D	E	F	G	OFF
NXA16, 20	0.2I _n	0.3I _n	0.4I _n	0.5I _n	0.6I _n	0.8I _n	I _n	
NXA32, 40, 63	500A	640A	800A	960A	1040A	1120A	1200A	
tg(s)	Inverse time limit	Action features						

P/H

NXA16, 20: 0.2I_n~1.0I_n+OFF

NXA32, 40, 63: 500A~1200A+OFF

$$t = \frac{(I_g)^2}{I^2} \times t_g$$

Constant time limit	Setting time (s)	0.1	0.2	0.3	0.4
	Minimum (s)	0.06	0.16	0.255	0.34
	Maximal (s)	0.14	0.24	0.345	0.46
	Return time	0.05	0.14	0.25	0.33

Note: I_g --- earth fault protection setting value. Default setting: NXA16/20: I_g = 0.5I_n

When I_n ≥ 1250A, I_g max = 1200A

NXA32/40/63: I_g = 800A

I --- failure current value

t --- failure action time-delay time

tg --- earthing inverse time limit set value

The permissible error of the inverse time limit action time: ± 15%

Conventional factory tuning: OFF

Controller minimum display current

Frame	I _n	Minimum display value (A)
1600	400 ~ 1600	60
2000	630 ~ 2000	60
≥ 3200	≥ 1600	120

Note: Controller can work normally when single phase not less than 0.4I_n, three phase not less than 0.2I_n.

Measurement precision of the intelligent controller

Current measurement	
Measurement range	Ia, Ib, Ic and I _n are not less than 15I _n (rated current of the circuit breaker)
Measurement precision	Below 0.1I _n : the measurement is inaccurate
	0.1I _n -0.4I _n : the accuracy will be changed linearly from 5% to 2%
	0.4I _n -1.5I _n : the accuracy is 2%
	>1.5I _n : the accuracy will be changed linearly from 2% to 15%
	The measurement accuracy of the earthing current is 10%

Voltage measurement	
Measurement range	Line voltage: 0V~600V Phase voltage: 0V~300V
Measurement precision	Error: ±1%

Frequency	
Measurement range	40HZ~70HZ
Measurement precision	Error: ± 0.1HZ

Power	
Measurement mode	The effective value mode
Measurement content	3P type: total active power, total reactive power and total apparent power
	4P type: phase splitting active power, phase splitting reactive power, phase splitting apparent power, total active power, total reactive power, total apparent power
Measurement power	Active power: -32768KW~ + 32767KW
	Reactive power: -32768Kvar~ + 32767Kvar
	Apparent power: 0KVA~65535KVA
	Error: ±2.5%

Power factor	
Measurement content	phase splitting power factor , total power factor
Measurement range	-1.00~+1.00

Electric energy	
Measurement content	Input reactive electric energy (EQ _{in}), output reactive electric energy (Eq _{out})
	Input active electric energy (EP _{in}), output active electric energy (Ep _{out})
	Total active electric energy (EP _{total}), total reactive electric energy (EQ _{total}), total apparent electric energy (Estotal)
Measurement range	Active electric energy: -32768KWh~ + 32767KWh
	Reactive electric energy: -32768Kvarh~ + 32767Kvarh
	Apparent electric energy: 0~65535KVAh
Measurement precision	Error ±2.5%

Harmonic wave measurement	
Fundamental wave measurement	Current: Ia, Ib, Ic, I _n
	Voltage: U _{an} , U _{bn} , U _{cn}
Total harmonic wave distortion THDu and thdu	THD: the total distortion rate of the harmonic wave relatively to the fundamental wave
	Thd: the total distortion rate of the harmonic wave relatively to the effective value
Amplitude wave spectrum of harmonic wave	The controller can display FFT amplitude of odd harmonic wave from 3 to 31in percentage
Measurement precision of control unit	±2%

LSI curves

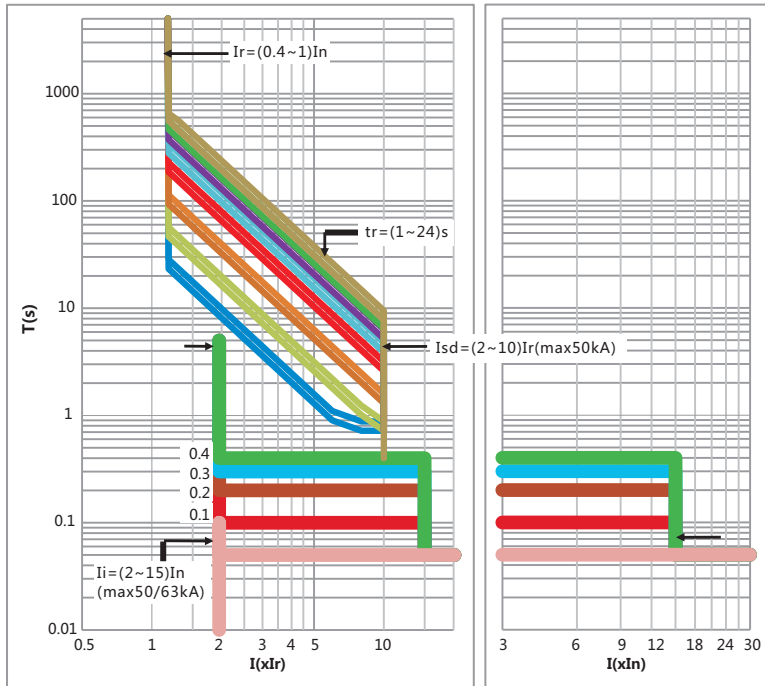

Fig.1 Overcurrent protection curves

Earth fault protection curves

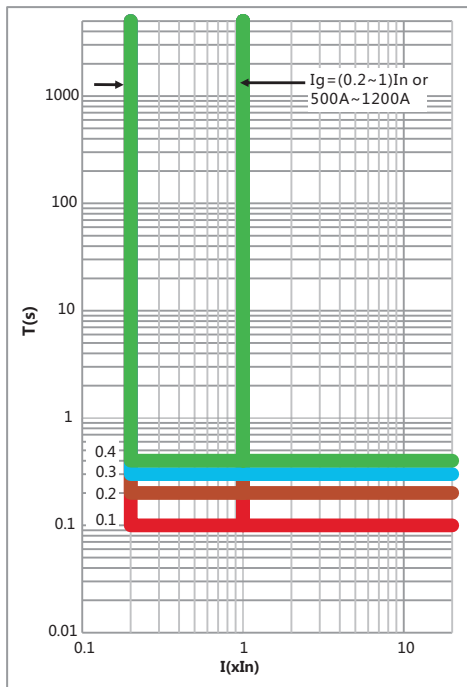

Fig.2 Asymmetrical earth fault protection curves



Accessories: locks

Pushbutton lock

The pushbutton lock is to lock the circuit breaker by a transparent cover blocks so as to prevent the breaking button and the making button of the circuit breaker from misoperation and guarantee the reliable running of the circuit breaker.

Body lock

- A key lock includes four types. The latter two are applied to 2 input and 1 connect power distribution system:

- Random lock
- One lock and one key
- Two locks and one key
- Three locks and two keys

Note: When the user separately purchases the key lock for installation, the panel needs to be opened with a hole opener, and the hole opener is provided by the user.

Hole diameter: NXA16:Φ21mm NXA20~63:Φ24mm

Safety shutters padlock

- The padlock is prepared by users. Diameter of the lock is no more than Φ5mm. when a circuit breaker body is at the disconnected or test part, the safety shutters automatically block access to the disconnecting contact cluster.

"Disconnected" position padlock

After the chassis and body are locked at "Disconnected" position by a padlock, the racking-handle cannot be inserted into racking-handle entry, and then the position of the body cannot be changed.

Door interlock

Circuit breaker state door interlock

A cabinet door is prohibited to be opened when the circuit breaker is closed.

The cabinet door is allowed to be opened when the circuit breaker is disconnected.

Circuit breaker position door interlock

The cabinet door is prohibited to be opened when the circuit breaker is at the connected and test part. The cabinet door is allowed to be opened when the circuit breaker is at the disconnected position.

Cable mechanical interlock

It can realize the interlock of two horizontal or vertical-installed, three poles or four poles, drawout type or fixed type circuit breaker.

Circuit diagram

Available running manner

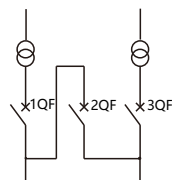

1QF	2QF	3QF
0	0	0
0	0	1
0	1	1
1	0	0
1	1	0
1	0	1

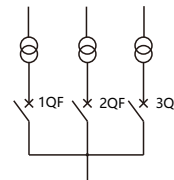

1QF	2QF	3QF
0	0	0
0	0	1
0	1	0
1	0	0

Note:a. If need bend the cable,make sure radian is more than 120°.

b. Check and make sure enough lubricating oil of the cable.

c. The maximum distance between two interlock circuit breakers is1.5m.

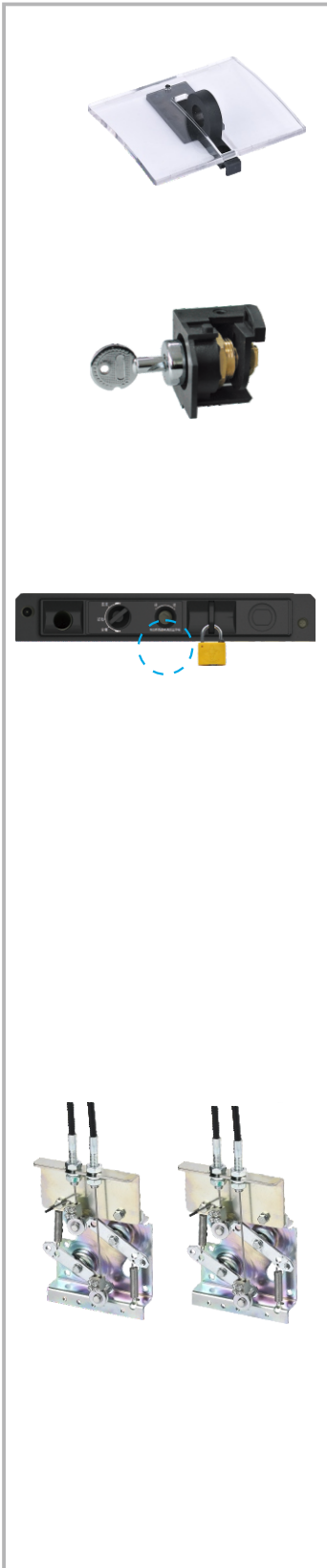



Accessories: indication contacts

ON/OFF indication contacts			
Standard configuration		4CO	6CO(for AC of NXA16 only)
Breaking capacity		Current (A) / Voltage (V)	Current (A) / Voltage (V)
Utilization category	VAC(AC-15)	1.3/240, 0.75/415	1.3/240, 0.75/415
	VDC(DC-13)	0.55/110, 0.27/220	0.55/110, 0.27/220

"Connected", "disconnected" and "test" position indication contact			
Standard configuration		1CO/3	
Breaking capacity		Current (A) / Voltage (V)	
Utilization category	VAC(AC-15)	1.3/240, 0.75/415	
	VDC(DC-13)	0.55/110, 0.27/220	

Alarming contact			
Standard configuration		1CO	
Breaking capacity		Current (A) / Voltage (V)	
Utilization category	VAC(AC-15)	1.3/240, 0.75/415	
	VDC(DC-13)	0.55/110, 0.27/220	

Spring charging indication contact			
Standard configuration		1NO	
Breaking capacity		Current (A)/ Voltage (V)	
Utilization category	VAC(AC-15)	1.3/240, 0.75/415	
	VDC(DC-13)	0.55/110, 0.27/220	

Note: ¹ CO refers to a switch contact, and a one-normally-open and one-normally-closed contact is matched with a common terminal.

² NO refers to a normally open contact. NC refers to a normally closed contact.

Source-changeover systems

- Mechanical interlock
 - 1 normal and 1 replacement
 - 2 incoming and 1 busbar
- Source-changeover controller (with adaptor)
 - 1 normal and 1 replacement: mechanical interlock+2A type controller
 - 2 incoming and 1 busbar: mechanical interlock+3A type controller





●Motor-driven mechanism (MO) (Standard configuration)
 When a circuit breaker is switched on, an motor operation mechanism stores energy automatically, so that when the circuit breaker is tripped, the device can switch on instantly. An energy-storage handle as spare when no auxiliary power supply is provided.

Characteristics		
Power supply	VAC 50/60HZ	220/230/240, 380/400/415
	VDC	110, 220
Operation threshold		0.85-1.1Us
Frame size: power loss (VA or W)		16: 75W; 20: 85W; 32: 110W; 40: 110W; 63: 150W
Motor overcurrent		≤1min
Charging time		≤7s
Operation frequency		≤2times/min

●Voltage coils (CC &ST) (Standard configuration)
 ●Closing coil (CC)
 After the energy storage of the motor is completed, the closed electromagnet can be operated and controlled within a range of 10 meters to instantaneously release the energy storage spring force of the operating mechanism to close the circuit breaker.

Rated control power supply voltage Us(V)	AC 220/230/240	AC 380/400/415	DC220	DC110	AC110 (not available for NXA16)		
Operation Voltage(V)	(0.85-1.1)Us						
Close time (ms)	≤50						
Power consumption (VA/W)	NXA16	pulse	56	56	250	250	-
		intermittent	300	300	132	70	300
	NXA20~63	pulse	880	1800	880	850	850

- Notes:
1. It must select pulse type in the automatic control system.
 2. power-on time of the intermittent type cannot be greater than 2 s, pulse frequency of the pulse type cannot be more than 5 times/min, or the components are easily burnt.
 3. Ensure that the product is in the energy storage state so that the closed electromagnet may be energized;
 4. If the product is not closed after a single power-on for 15s, must disconnect the power on the closed electromagnet immediately.

●Shunt release (ST)
 The power-on time cannot be greater than 2 seconds / time, and the power-on frequency cannot be greater than 5 times / minute.
 a. The shunt release should be used except for special products where the circuit breaker must be directly disconnected manually;
 b. The shunt release could operated within 10 meters to break the circuit breaker.

Rated control power supply voltage Us(V)	AC 220/230/240	AC 380/400/415	DC220	DC110	AC110 (not available for NXA16)		
Operation Voltage(V)	(0.7-1.1)Us						
Break time (ms)	≤28						
Power consumption (VA/W)	NXA16	pulse	56	56	250	250	-
		intermittent	300	300	132	70	300
	NXA20~63	pulse	880	1800	880	850	850

- Notes:
1. It must select pulse type in the automatic control system.
 2. power-on time of the intermittent type cannot be greater than 2 s, pulse frequency of the pulse type cannot be more than 5 times/min, or the components are easily burnt;
 3. If the circuit breaker is not break by a single power-on of 15 s, must disconnect the power on the shunt release immediately.



1600A frame UVT 2000~4000A frame UVT

6300A frame ASUVT

2000~4000A frame UVTD

● Undervoltage release (UVT)

Under-voltage release (UVT) (Optional, The power must be turned on before the circuit breaker is closed)

The under-voltage release has instantaneous operation and delayed operation:

Operation types of each frame under-voltage release		
	Self-priming	Helped priming
Under-voltage instantaneous release	Inm=1600A, 6300A	Inm=2000A, 3200A, 4000A
Under-voltage delay release	Inm=1600A, 6300A	Inm=2000A, 3200A, 4000A

Notes:

1. Inm=1600A under-voltage delay does not require an external delay controller. The power-off operation is an instantaneous operation. There is no zero voltage delay function;
2. Inm=6300A under-voltage delay does not require an external under-voltage delay controller. There is a delay function for low voltage and power off;
3. Inm=2000A~4000A under-voltage delay requires an external delay controller. There is a delay operation when the power is off. There is a zero voltage delay function.

Delay time of under-voltage release	Delay time (optional)	Accuracy
Inm=1600A	1 s, 3 s, 5 s, 7 s (not adjustable)	±15%
Inm=2000A~4000A	1 s, 3 s, 5 s (not adjustable)	0~1s
Inm=6300A	0.3 s~7.5 s (adjustable)	±15%

The under-voltage will not operate when the voltage returns to 85% Ue and higher, within 1/2 delay time.

Note:

A self-priming under-voltage delay release may be provided for special orders of NXA20~63. There is no external under-voltage delay controller, and the delay time is 0.3s~7.5s, selectable and adjustable with an accuracy of ±15%.

When the under-voltage release is not powered, the circuit breaker cannot be closed either electrically or manually.

Characteristics of under-voltage release	
Rated control power supply voltage Ue(V)	Ac110. AC220/230/240. AC380/400/415
Operating voltage (V)	(0.35~0.7)Ue
Reliable closing voltage (V)	(0.85~1.1)Ue
Reliable not-closing voltage (V)	≤0.35Ue
Power consumption (Inm=1600A/Inm=2000A~6300A)	20VA/48VA (W)



Capacity derating and power loss

Temperature capacity derating table of the fixed type circuit breaker

1600A frame

Ambient temperature	400A		630A		800A		1000A		1250A		1600A	
Connection mode	Horizontal	Vertical	Horizontal	Vertical	Horizontal	Vertical	Horizontal	Vertical	Horizontal	Vertical	Horizontal	Vertical
40°	-	-	-	-	-	-	-	-	-	-	-	-
45°	-	-	-	-	-	-	-	-	-	-	-	-
50°	-	-	-	-	-	-	-	-	-	-	1550	1600
55°	-	-	-	-	-	-	-	-	1150	1200	1500	1550
60°	-	-	550	580	-	-	-	-	1050	1100	1450	1500

2000A frame

Ambient temperature	630A		800A		1000A		1250A		1600A		2000A	
Connection mode	Horizontal	Vertical	Horizontal	Vertical	Horizontal	Vertical	Horizontal	Vertical	Horizontal	Vertical	Horizontal	Vertical
40°	-	-	-	-	-	-	-	-	-	-	-	-
45°	-	-	-	-	-	-	-	-	1550	-	1900	-
50°	-	-	-	-	-	-	-	-	1500	1550	1850	1900
55°	-	-	-	-	-	-	-	-	1400	1450	1800	1800
60°	-	-	-	-	-	-	-	-	1300	1350	1700	1700

3200A frame

Ambient temperature	1600A		2000A		2500A		3200A	
Connection mode	Horizontal	Vertical	Horizontal	Vertical	Horizontal	Vertical	Horizontal	Vertical
40°	-	-	-	-	-	-	-	-
45°	-	-	-	-	-	-	-	-
50°	-	-	-	-	-	-	3100	-
55°	-	-	-	-	2450	-	3000	3050
60°	-	-	-	-	2350	2400	2900	2950

4000A frame

Ambient temperature	3200A		3600A		4000A	
Connection mode	Horizontal	Vertical	Horizontal	Vertical	Horizontal	Vertical
40°	-	-	-	-	-	-
45°	3100	-	-	-	3800	3850
50°	3000	-	-	-	3600	3650
55°	3000	3050	3400	3450	3400	3450
60°	2900	2900	3200	3250	3200	3250

6300A frame

Ambient temperature	4000A		5000A		6300A	
Connection mode	Horizontal		Horizontal		Horizontal	
40°	-		-		-	
45°	-		-		-	
50°	-		-		5600	
55°	-		4800		5400	
60°	-		4800		5200	

Note: "-" refers to no capacity derating.

Temperature capacity derating table of the draw-out type circuit breaker

1600A frame

Ambient temperature	400A		630A		800A		1000A		1250A		1600A	
Connection mode	Horizontal	Vertical	Horizontal	Vertical	Horizontal	Vertical	Horizontal	Vertical	Horizontal	Vertical	Horizontal	Vertical
40°	-	-	-	-	-	-	-	-	-	-	-	-
45°	-	-	-	-	-	-	-	-	-	-	1550	-
50°	-	-	-	-	-	-	-	-	1150	1200	1500	1550
55°	-	-	550	580	-	-	-	-	1050	1100	1450	1500
60°	-	-	500	530	-	-	950	-	950	1000	1400	1450

2000A frame

Ambient temperature	630A		800A		1000A		1250A		1600A		2000A	
Connection mode	Horizontal	Vertical	Horizontal	Vertical	Horizontal	Vertical	Horizontal	Vertical	Horizontal	Vertical	Horizontal	Vertical
40°	-	-	-	-	-	-	-	-	-	-	-	-
45°	-	-	-	-	-	-	-	-	1500	-	1850	1900
50°	-	-	-	-	-	-	-	-	1400	1500	1750	1850
55°	-	-	-	-	-	-	-	-	1300	1400	1650	1750
60°	600	-	-	-	-	-	1200	-	1200	1300	1550	1650

3200A frame

Ambient temperature	1600A		2000A		2500A		3200A	
Connection mode	Horizontal	Vertical	Horizontal	Vertical	Horizontal	Vertical	Horizontal	Vertical
40°	-	-	-	-	-	-	-	-
45°	-	-	-	-	2450	-	3100	-
50°	-	-	-	-	2400	2450	3000	3100
55°	-	-	-	-	2350	2400	2900	3000
60°	-	-	-	-	2300	2350	2800	2900

4000A frame

Ambient temperature	3200A		3600A		4000A	
Connection mode	Horizontal	Vertical	Horizontal	Vertical	Horizontal	Vertical
40°	-	-	-	-	-	-
45°	3100	-	-	-	3800	3850
50°	3000	3100	-	-	3600	3650
55°	2900	3000	3400	3450	3400	3450
60°	2800	2900	3200	3250	3200	3250

6300A frame

Ambient temperature	4000A		5000A		6300A	
Connection mode	Horizontal		Horizontal		Horizontal	
40°	-		-		-	
45°	-		-		-	
50°	-		-		5600	
55°	-		4800		5400	
60°	-		4800		5200	

Note: "-" refers to no capacity derating.

Altitude capacity derating factor

Altitude height (m)		2000	3000	4000	5000
Rated impulse withstand voltage (kV)	Uimp	12	10	8.57	7.5
Average insulation grade (V)	Ui	1000	833	714	625
Maximal operational voltage (V) 50/60HZ	Ue	690	580	500	415
Average heat operational current(40)°C		1.0	0.88	0.78	contact with factory

Power loss and input and output resistance

Power loss is the power loss of each pole measured at In, 50/60Hz. The input/output resistance is the DC resistance value of each pole at the cold state.

Frame size	Rated current (A)	Draw-out type		Fixed type (W)	
		Power loss (W)	Input/output resistance (μohm)	Power loss (W)	Input/output resistance (μohm)
1600A	400	30.5	63.6	15.6	32.4
	630	75.7	63.6	38.6	32.4
	800	99.1	51.6	54.1	28.2
	1000	154.8	51.6	84.6	28.2
	1250	241.9	51.6	132.2	28.2
	1600	262.7	34.2	138.2	18.0
2000A	630	58.6	49.2	26.4	22.2
	800	73.7	38.4	36.6	19.1
	1000	115.2	38.4	57.2	19.1
	1250	180	38.4	89.4	19.1
	1600	294.9	38.4	146.5	19.1
	2000	388.8	32.4	204.5	17.0
3200A	1600	127.2	16.6	60.1	7.8
	2000	198.7	16.6	93.9	7.8
	2500	310.5	16.6	146.7	7.8
	3200	479.2	15.6	206.4	6.8
4000A	3200	435	14.1	239.6	7.8
	3600	690.5	17.7	272.9	7.0
	4000	852.5	17.7	337	7.0
6300A	4000	403.2	9.0	230.4	7.0
	5000	630	9.0	360	7.0
	6300	1000.2	8.8	571	6.4

Dimension of busbar

Bolt configuration

Type of bolt	Application	Fastening busbar
16: M10	Fastening busbar	(36~52)N·m
20~63: M12	Fastening busbar	(61~94)N·m
16~63: M3	Fastening secondary connector	(0.4~0.5)N·m

Hole size and installation twisting moment of busbar

DrillingΦ (mm)	Diameter of bolt	Fastening twisting moment
16:Φ11	M10	(36~52)N·m
20~63:Φ13	M12	(61~94)N·m

Connection busbar specification reference under different temperature

Maximum permissible temperature of busbar: 100°C
 The material of busbar is bare copper

Frame	Rated current (A)	Ambient temperature(-45~40)°C				Ambient temperature 50°C				Ambient temperature 60°C			
		5mm thick busbar		10mm thick busbar		5mm thick busbar		10mm thick busbar		5mm thick busbar		10mm thick busbar	
		Number of pieces	Specification	Number of pieces	Specification	Number of pieces	Specification	Number of pieces	Specification	Number of pieces	Specification	Number of pieces	Specification
1600A	400	2	50*5	1	50*10	2	50*5	1	50*10	2	50*5	1	50*10
	630	2	50*5	1	50*10	2	50*5	1	50*10	2	50*5	1	50*10
	800	2	50*5	1	50*10	2	50*5	1	50*10	2	50*5	1	50*10
	1000	3	50*5	2	50*10	3	50*5	2	50*10	3	50*5	2	50*10
	1250	4	50*5	2	50*10	4	50*5	2	50*10	4	50*5	2	50*10
	1600	4	50*5	2	50*10	4	50*5	2	50*10	4	50*5	2	50*10
2000A	630	2	50*5	1	50*10	2	50*5	1	50*10	2	60*5	1	60*10
	800	2	50*5	1	50*10	2	50*5	1	50*10	2	60*5	1	60*10
	1000	3	50*5	2	50*10	3	50*5	2	50*10	3	60*5	2	50*10
	1250	3	60*5	2	50*10	3	60*5	2	50*10	3	60*5	2	50*10
	1600	4	60*5	2	60*10	4	60*5	2	60*10	4	60*5	2	60*10
	2000	6	60*5	3	60*10	6	60*5	3	60*10	6	60*5	3	60*10
3200A	1600	2	100*5	1	100*10	2	100*5	1	100*10	2	100*5	1	100*10
	2000	4	100*5	2	100*10	4	100*5	2	100*10	4	100*5	2	100*10
	2500	4	100*5	2	100*10	4	100*5	2	100*10	4	100*5	2	100*10
	3200	8	100*5	4	100*10	8	100*5	4	100*10	8	100*5	4	100*10
4000A	3200	8	100*5	4	100*10	8	100*5	4	100*10	8	100*5	4	100*10
	3600	7	120*5	3	120*12	7	120*5	3	120*12	7	120*5	3	120*12
	4000	8	120*5	4	120*10	8	120*5	4	125*10	8	125*5	4	125*10
6300A	4000	12	100*5	6	100*10	12	100*5	6	100*10	14	100*5	7	100*10
	5000	14	100*5	7	100*10	14	100*5	7	100*10	16	100*5	8	100*10
	6300	16	100*5	8	100*10	16	100*5	8	100*10	18	100*5	9	100*10

Note:

- When a copper bar selected by users is not matched with a wiring terminal of the circuit breaker, extended busbar is required to be designed to transfer, and is designed by the users of their own. The cross section of the extended busbar cannot be less than the requirement in the table above. The interval among the extended busbar is not less than the interval among wiring terminals of the circuit breaker.
- After the busbar recommended in the table above is installed, the electric clearance between adjacent phases of the circuit breaker is not less than 18mm.
- Electrical elements are used for three-phase rectification and high-frequency inversion, such as a high-frequency induction heating furnace (medium-frequency furnace steelmaking equipment), a solid high-frequency welding machine (such as an embedded arc electric welding machine), vacuum heating smelting equipment (such as a monocrystalline silicon growth furnace), in load equipment by controlled silicon. When a circuit breaker is selected, the influence on the circuit breaker by higher order harmonic component generated by controlled silicon is required to be considered besides the influences by the environment temperature and altitude height. At the same time, capacity derating is required, and the capacity coefficient (0.5-0.8) is recommended.
- The electric clearance of fastening bolts of upper and lower busbar needs to be not less than 20mm after the installation of the busbar by users.
- After the installation of the circuit breaker, the safety clearance among electrified bodies with different electric potential and between the electrified bodies and the ground are not less than 18mm.



Dimensions and installation

1600A fixed type

Front view

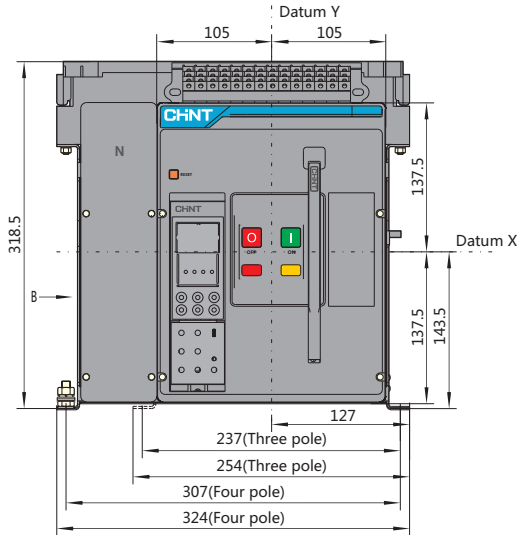

Side view

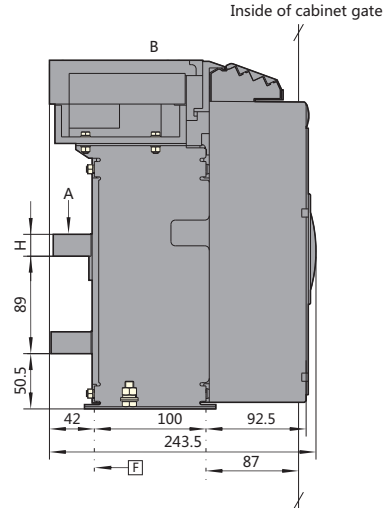

Hole size

Hole size of the base

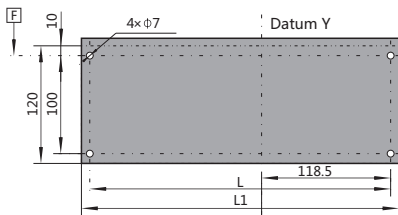

Schematic diagram of the overall size of the bottom surface and the installation hole pitch

H	L	L1	Remark
5	237	254	In=400A~630A Fixed type, three pole
8	237	254	In=800A~1250A Fixed type, three pole
20	237	254	In=1600A Fixed type, three pole
5	307	324	In=400A~630A Fixed type, four pole
8	307	324	In=800A~1250A Fixed type, four pole
20	307	324	In=1600A Fixed type, four pole

Hole size of a panel

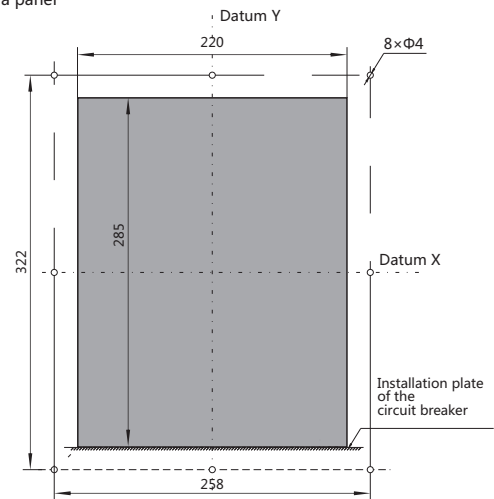

Hole size of the panel of the fixed type circuit breaker

Horizontal connection

Side view

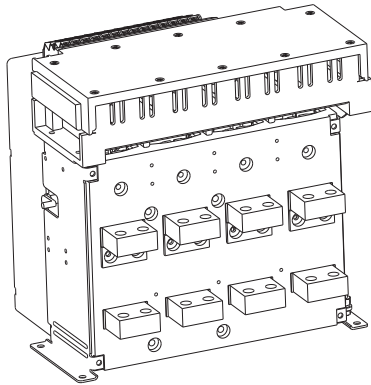

Busbar size and busbar interval

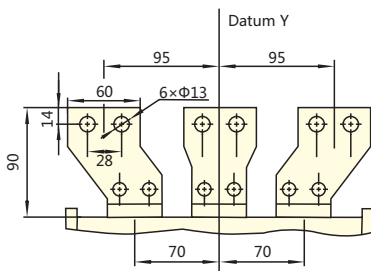
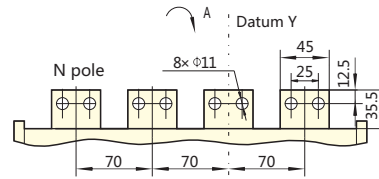

(Optional)

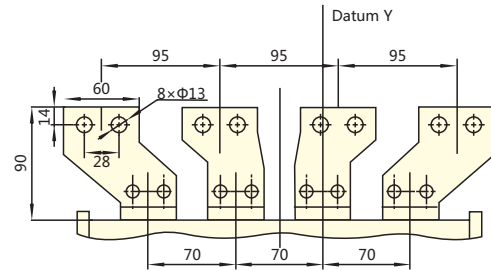

(Optional)

Number of busbar

"Rated current (A) "	Number of pieces			
	Three poles		Four poles	
	A pole+C pole	B pole	A pole+B pole	C pole+N pole
400 ~ 630	4	2	4	4
800 ~ 1250	4	2	4	4
1600	8	4	8	8



1600A draw-out type

Front view

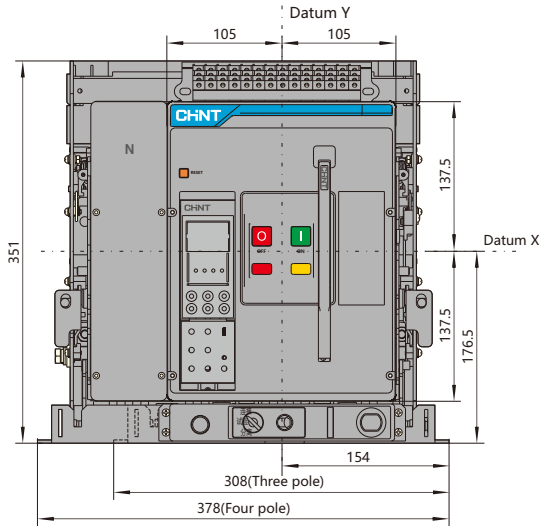

Side view

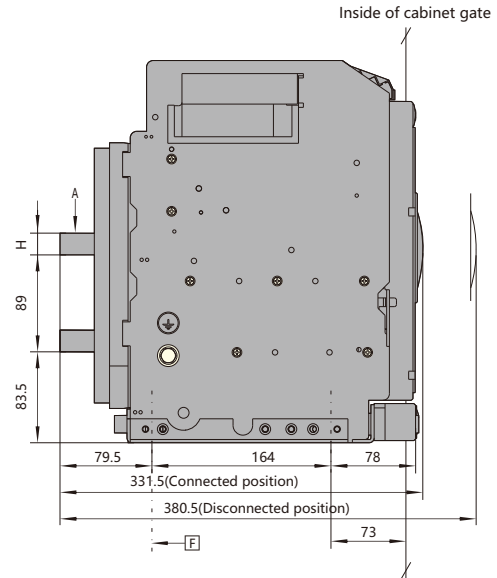

Hole size

Hole size of the base

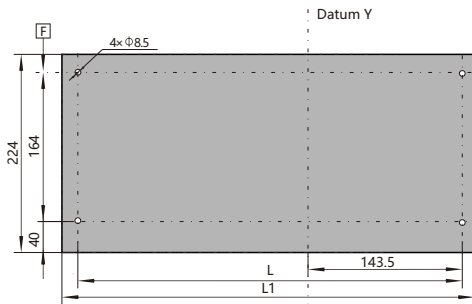

Schematic diagram of the overall size of the bottom surface and the installation hole pitch

H	L	L1	Remark
5	287	308	In=400A~630A Three pole
8	287	308	In=800A~1250A Three pole
20	287	308	In=1600A Three pole
5	357	378	In=400A~630A Four pole
8	357	378	In=800A~1250A Four pole
20	357	378	In=1600A Four pole

Hole size of a panel

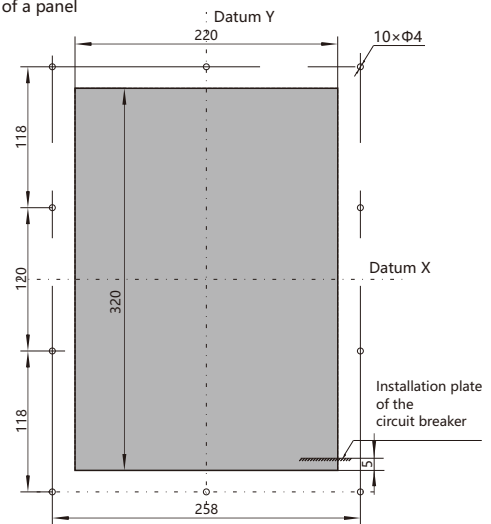

Ratio: 1:1.5 Hole size of a panel of the draw-out type circuit breaker

Horizontal connection

Side view

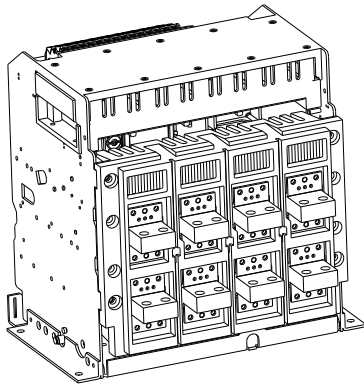

Busbar size and interval

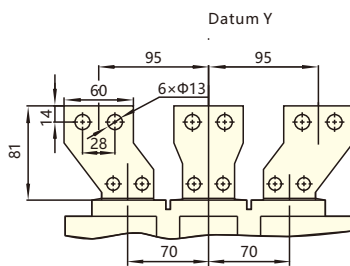
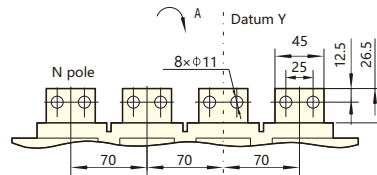

Optional

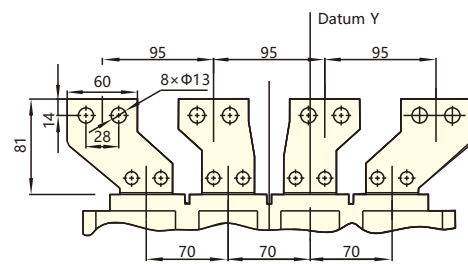

Optional

Number of busbar

"Rated current (A) "	Number of pieces			
	Three poles		Four poles	
	A pole+C pole	B pole	A pole+B pole	C pole+N pole
400 ~ 630	4	2	4	4
800 ~ 1250	4	2	4	4
1600	8	4	8	8



2000A fixed type

Front view

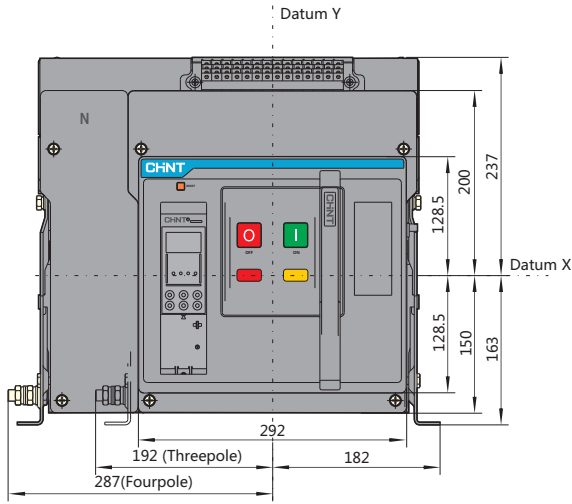

Side view

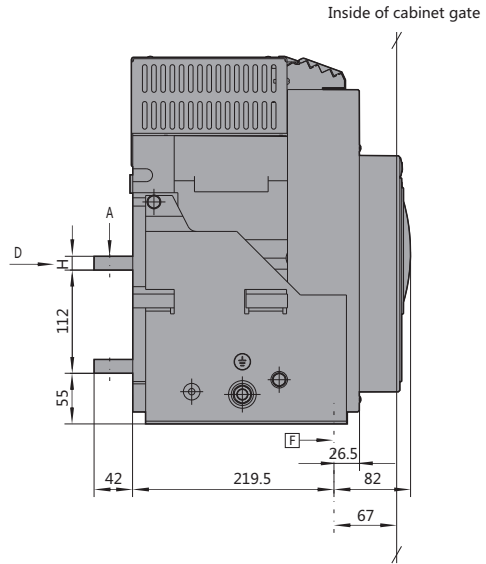

Hole size

Hole size of the base

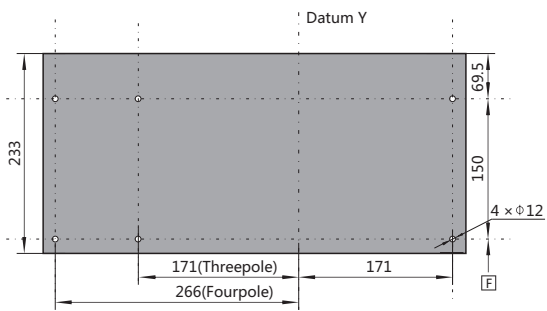

Schematic diagram of the overall size of the bottom surface and the installation hole pitch

Hole size of a panel

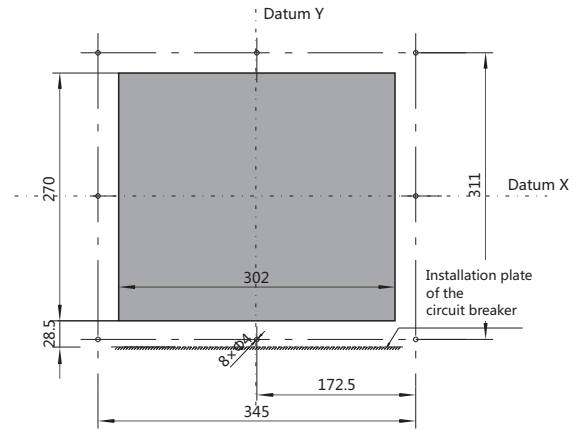

Hole of the panel

H	Remark
10	In=630A
15	In=800A~1600A
20	In=2000A

Horizontal connection

Side view

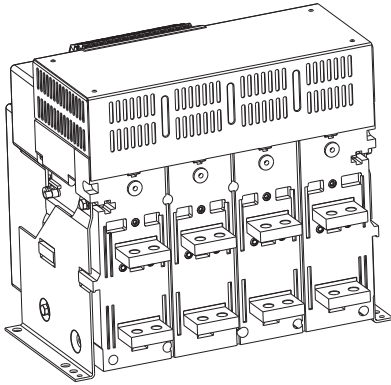

Busbar size and interval

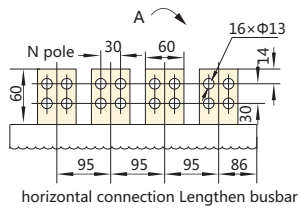
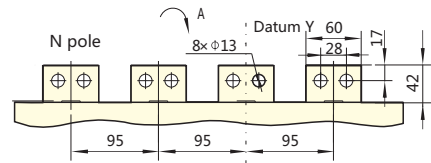

horizontal connection Lengthen busbar

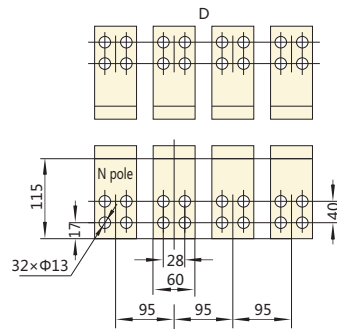

L type vertical connection



2000A draw-out type

Front view

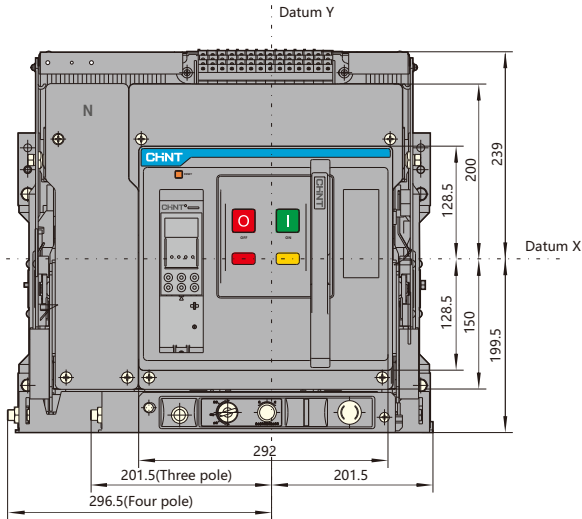

Side view

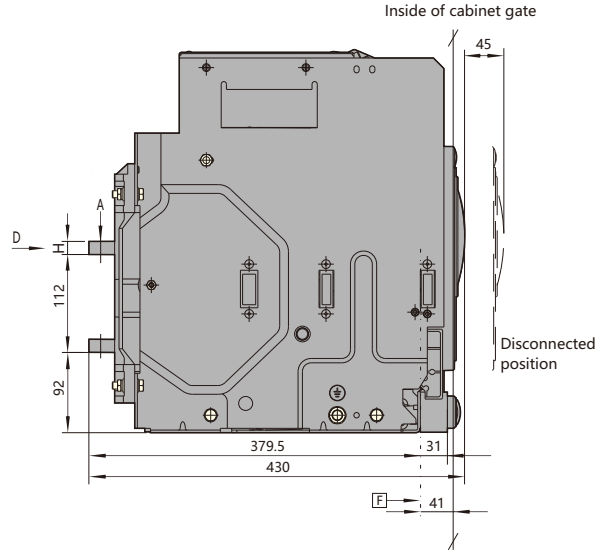

Hole size

Hole size of the base

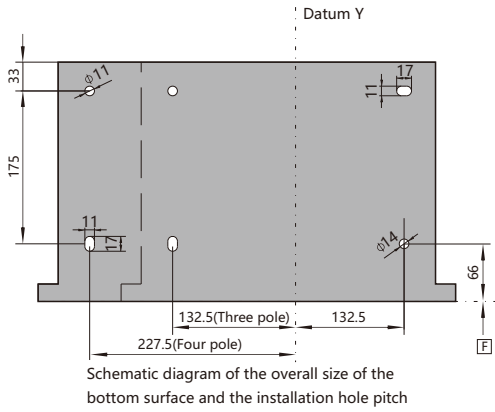

Hole size of a panel

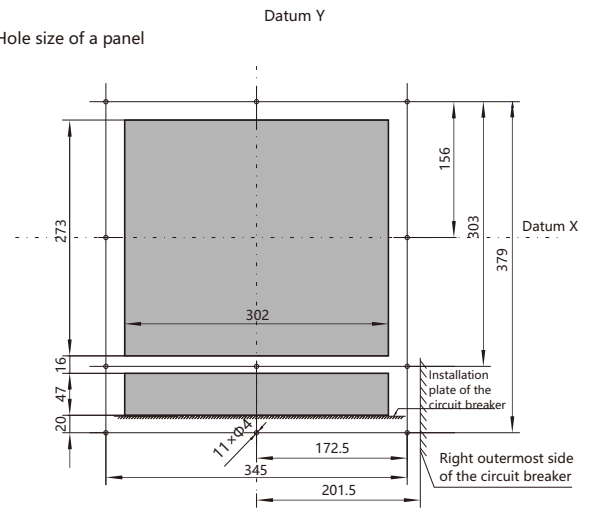

Hole of the panel

H	Remark
10	In=630A
15	In=800A~1600A
20	In=2000A

Horizontal connection

Side view

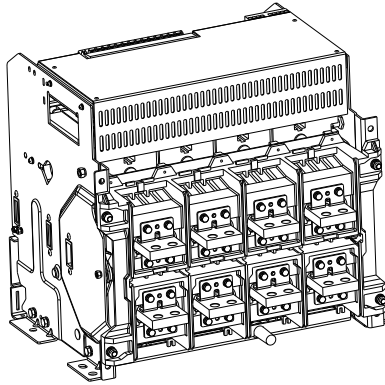

Busbar size and interval

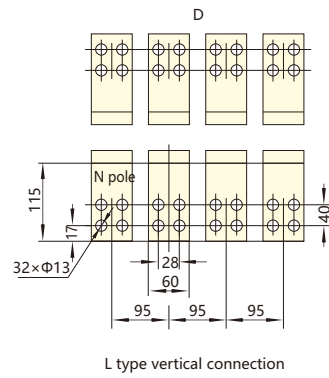
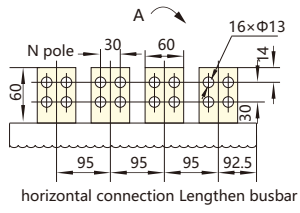
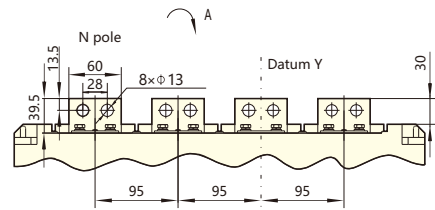

3200A fixed type

Front view

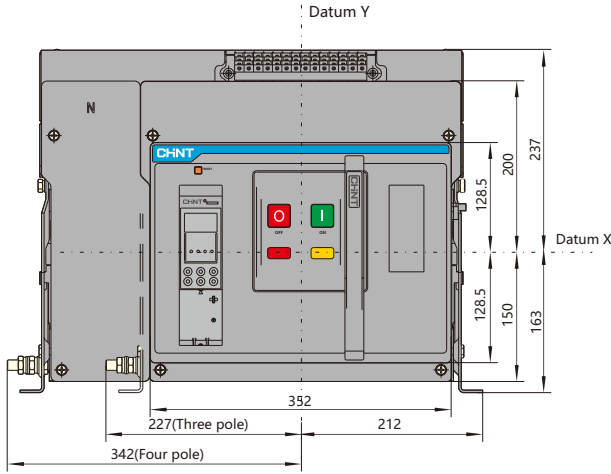

Side view

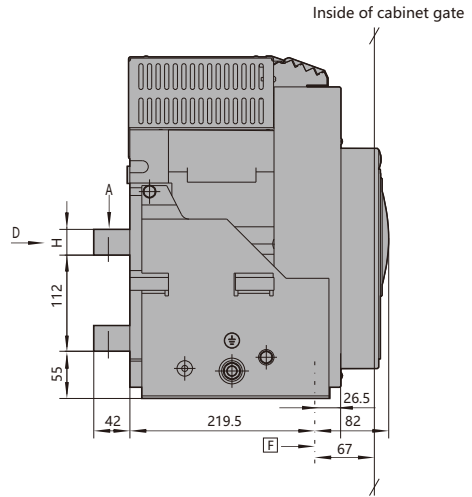

Hole size

Hole size of the base

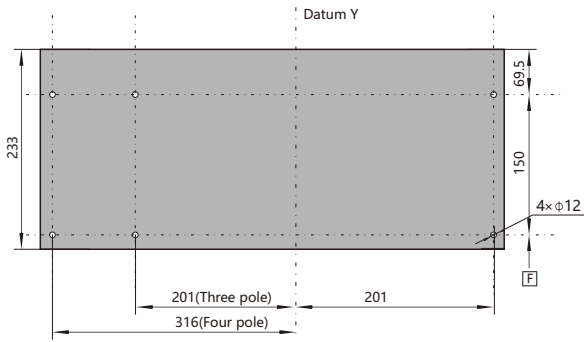

Schematic diagram of the overall size of the bottom surface and the installation hole pitch

Hole of the panel

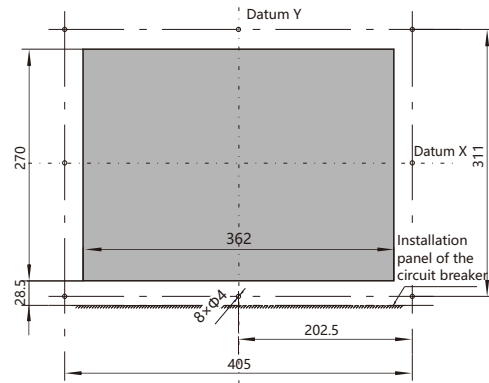

Horizontal connection

H	Remark
20	In=1600A~2500A
30	In=3200A

Horizontal connection

Side view

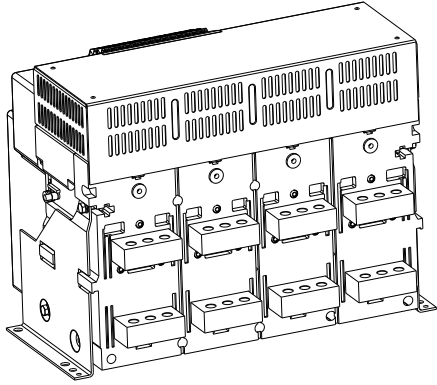

Busbar size and interval

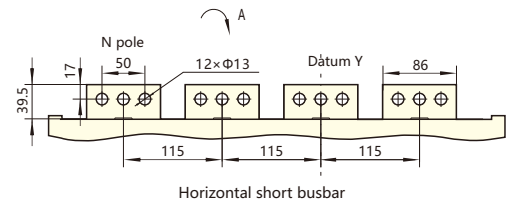
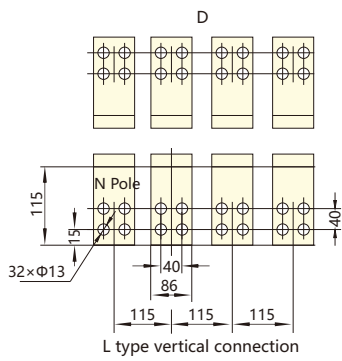
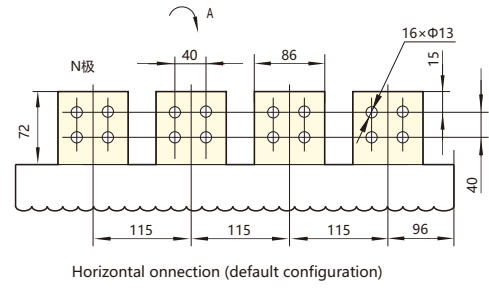

3200A draw-out type(Default configuration)

Front view

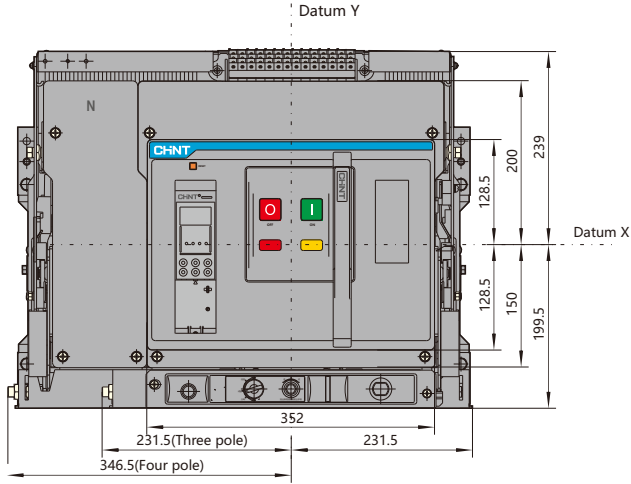

Side view

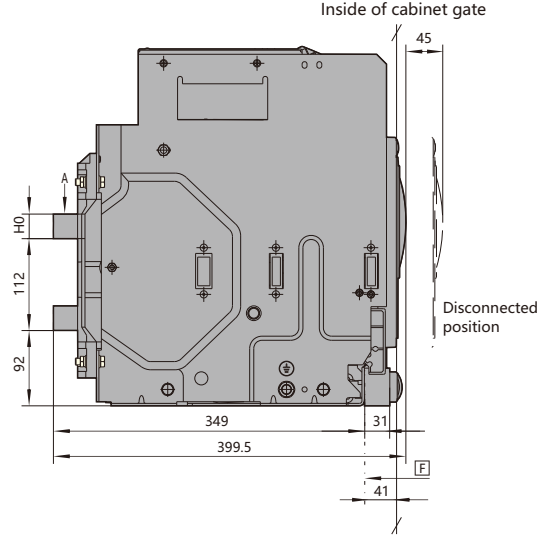

3200A draw-out type(Horizontal short busbar)

Front view

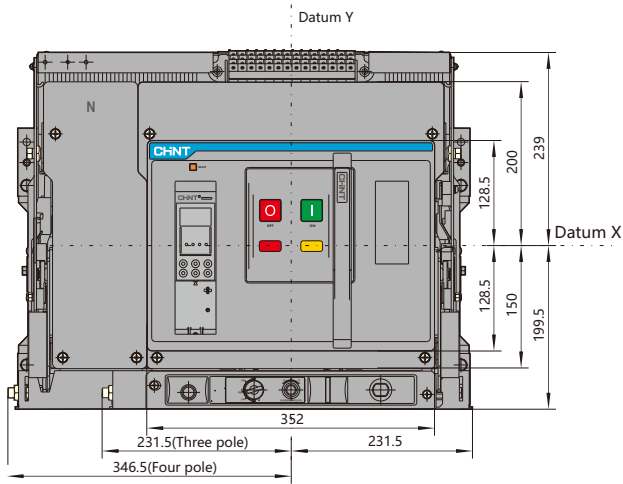

Side view

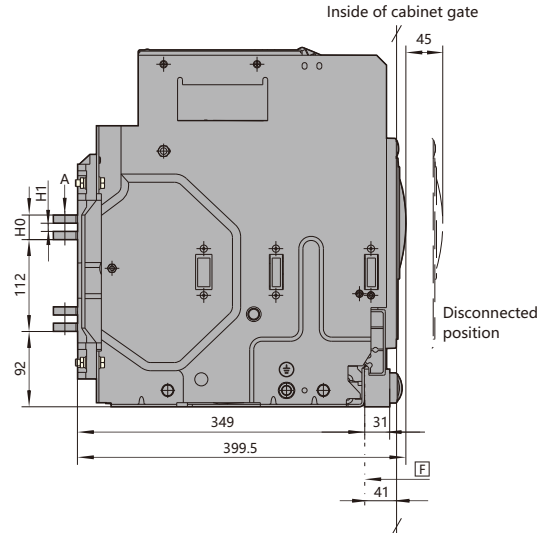

Horizontal connection

Side view

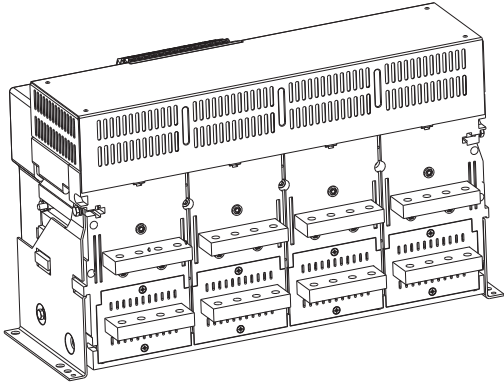

Busbar size and interval

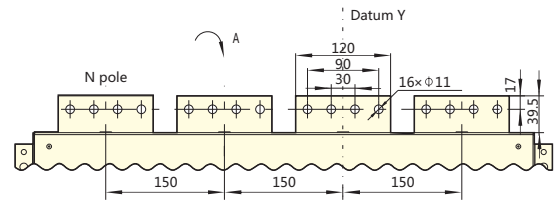

4000A draw-out type

Front view

Side view

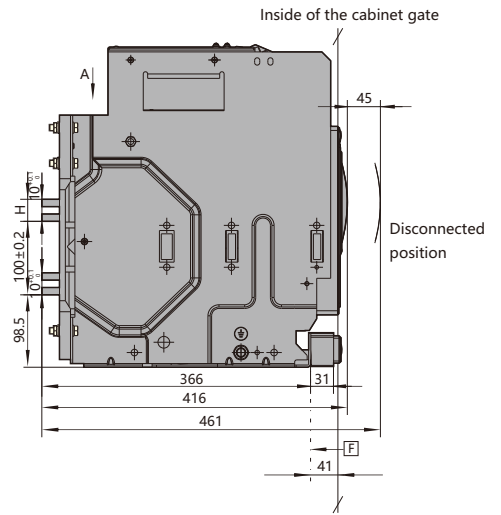
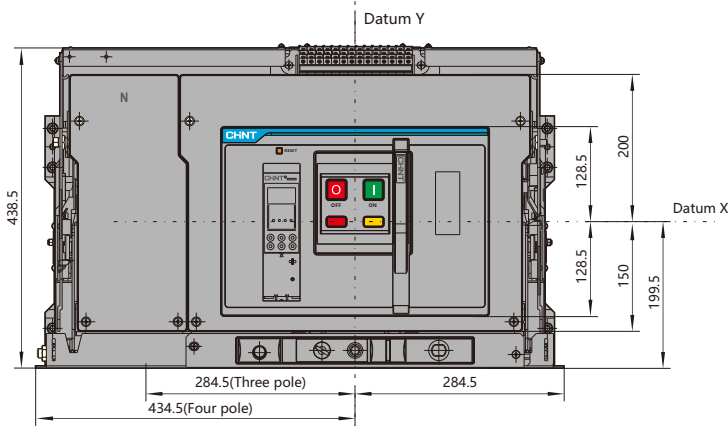

Hole size

Hole size of the base

Hole size of a panel

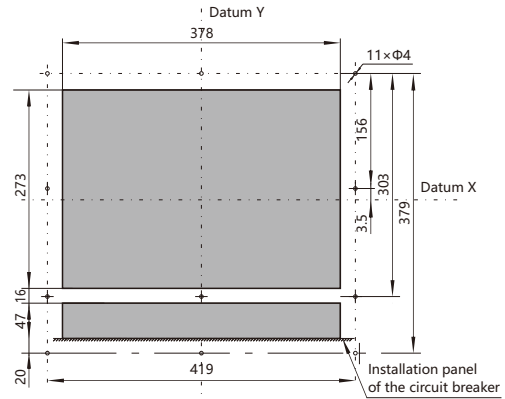
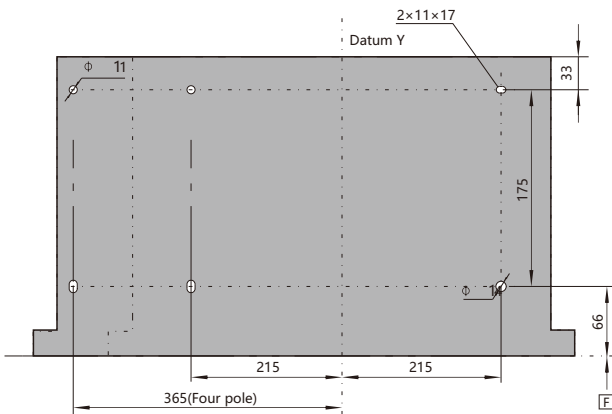

Schematic diagram of the overall size of the bottom surface and the installation hole pitch

Ratio 1:1 Hole size of the panel of the draw-out type circuit breaker

H	Remark
26	In=3200A
30	In=3600~4000A

Horizontal connection

Side view

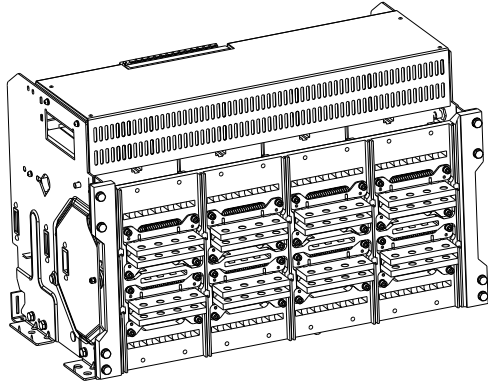

Busbar size and interval

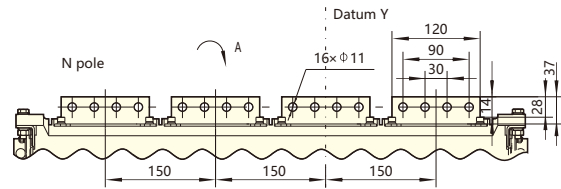

6300A fixed type

Front view

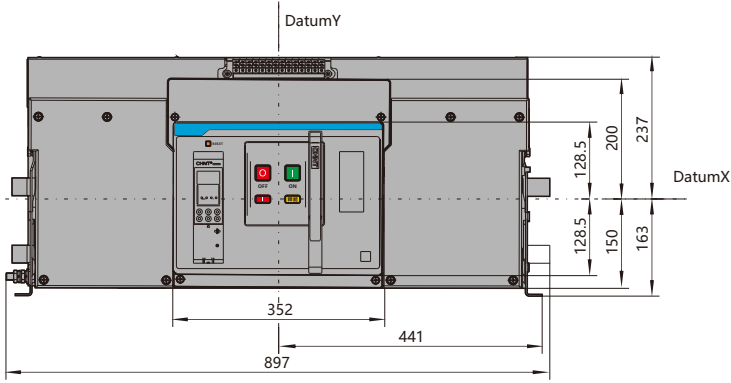

Side view

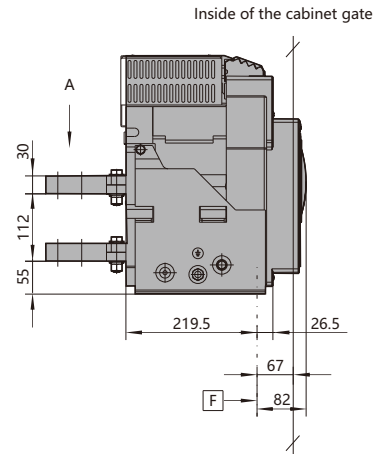

Hole size

Hole size of the base

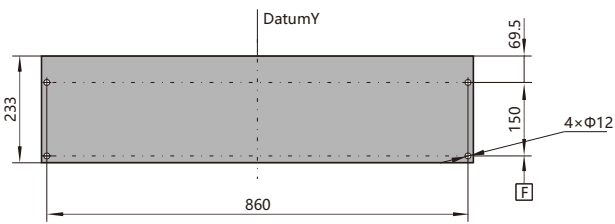

Schematic diagram of the overall size of the bottom surface and the installation hole pitch

Hole size of panel

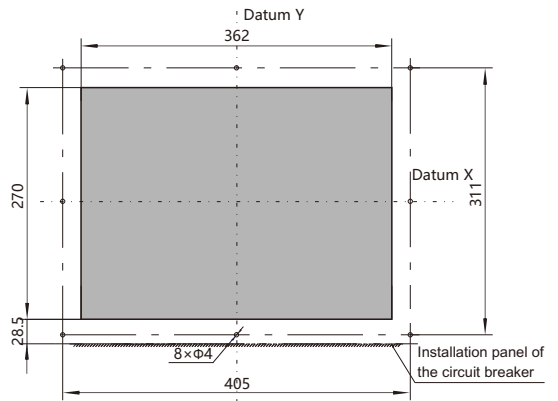

Hole size of the panel of the fixed type circuit breaker

Horizontal connection

Side view

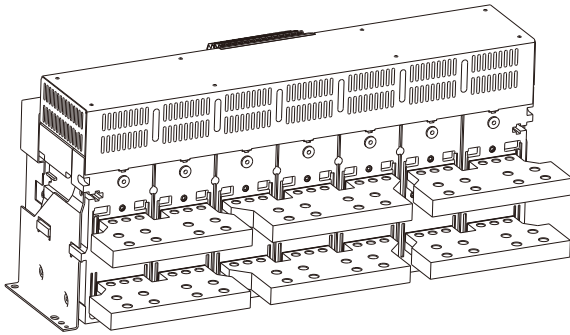

Busbar size and interval

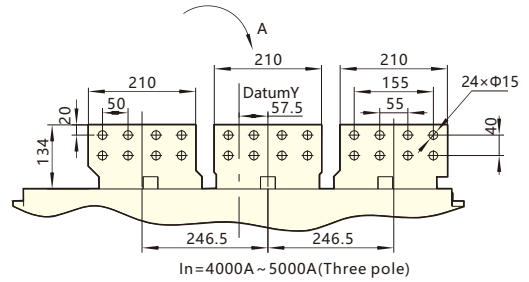
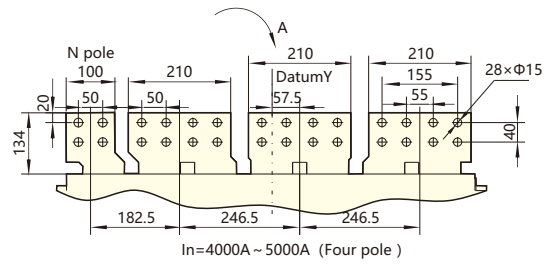
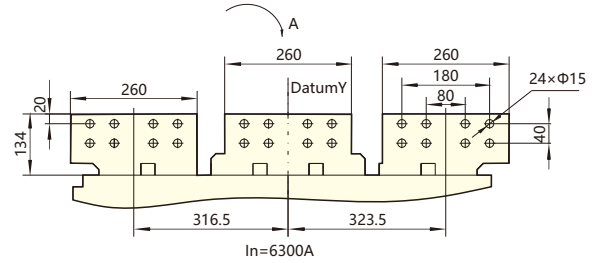

6300A draw-out type

Front view

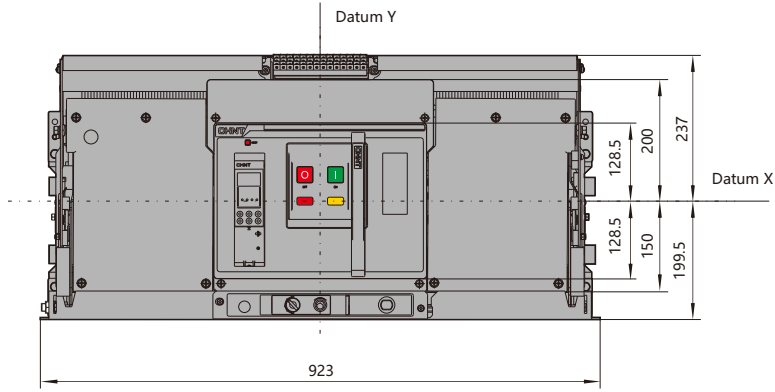

Side view

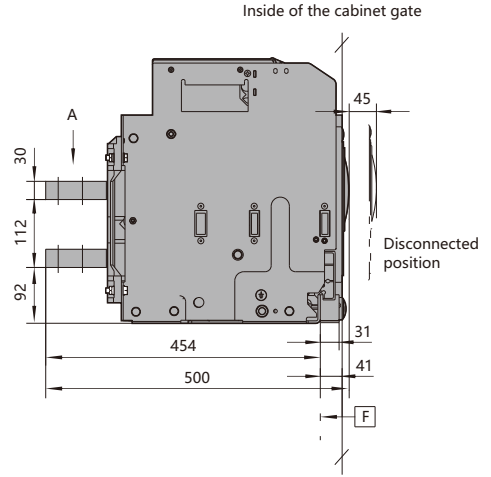

Hole size

Hole size of the base

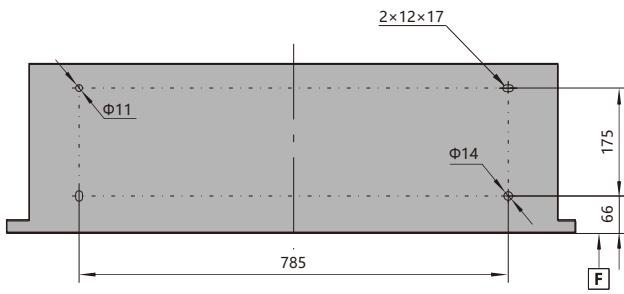

Hole size of the panel of the fixed type circuit breaker

Hole size of panel

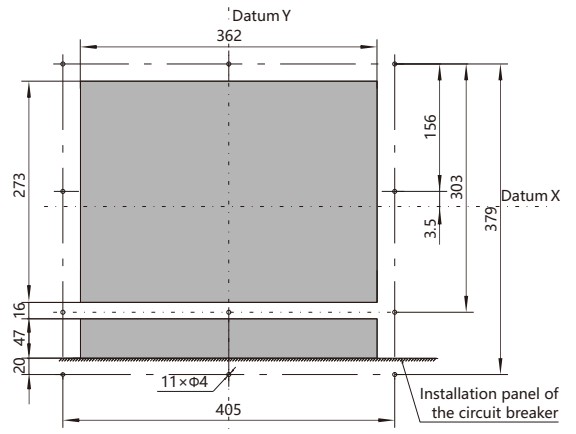

Hole size of the panel of the draw-out type circuit breaker

Horizontal connection

Side view

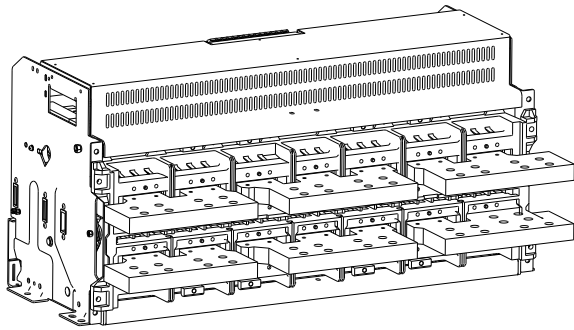

Busbar size and interval

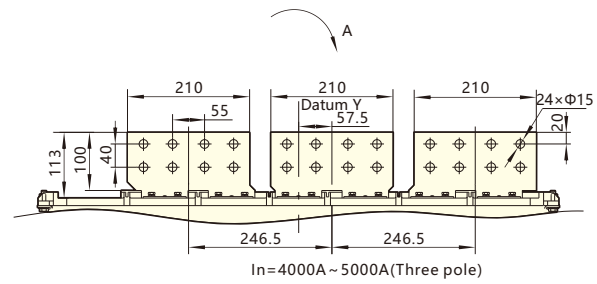
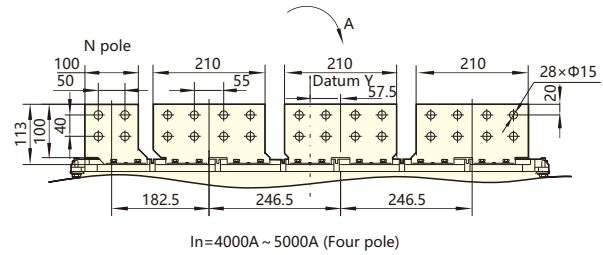
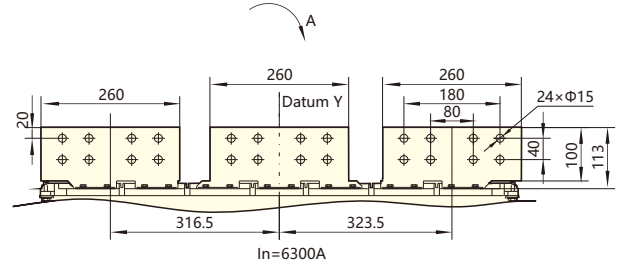

External transformer (Neutral CT) (3P+N mode)

External transformer (Neutral CT) dimension

The installation overall dimension of an external N-phase transformer is as below when the controller is of 3P+N type.
The transformer is provided by the manufacturer. A connection copper bar and an installation support are manufactured by users.

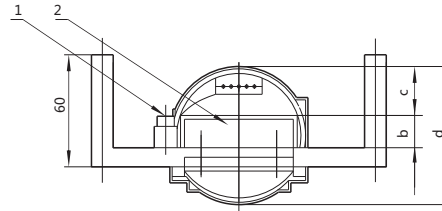
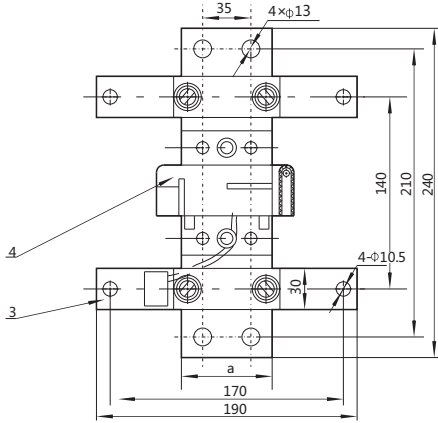

1-Wiring panel 2-Busbar 3-Fixation panel 4-Transformer

Frame size	a	b	c	d
1600	45	20	40	88
2000	60	20	34	89
3200	80	20	35	110
4000	120	20	16	58
6300	80	20	35	110

4CT Type earth current transformer

Structural dimension of external earth current transformer (W type)

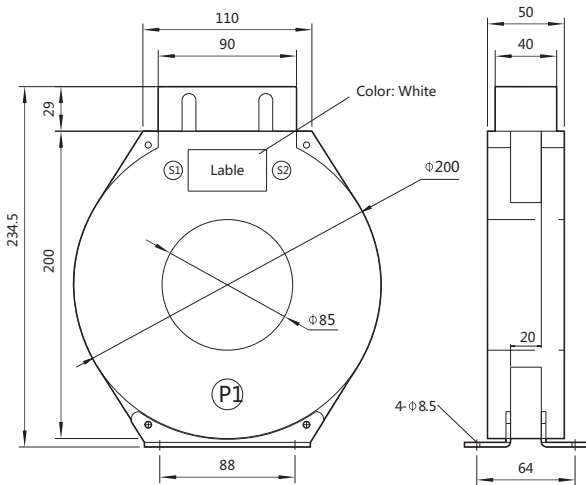

CTB-2 Type earth current transformer

Structural dimension of external earth current transformer (W type)

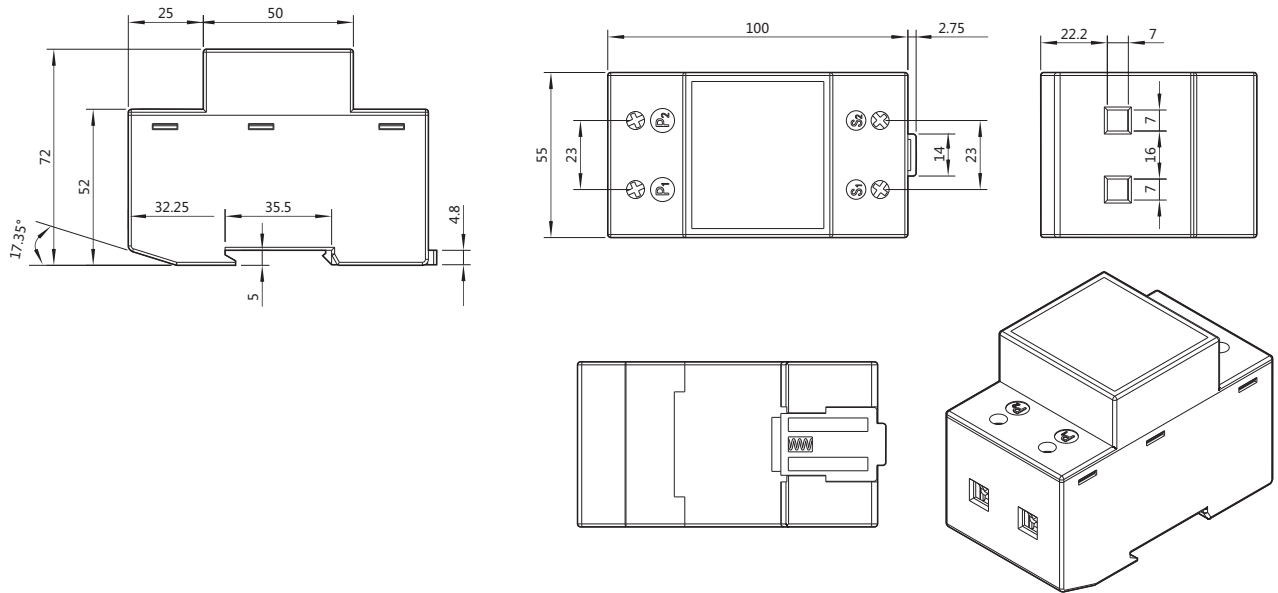

Undervoltage time delay controller

Installation overall dimension of undervoltage time-delay controller which is required to be plugged in the undervoltage time-delay tripper

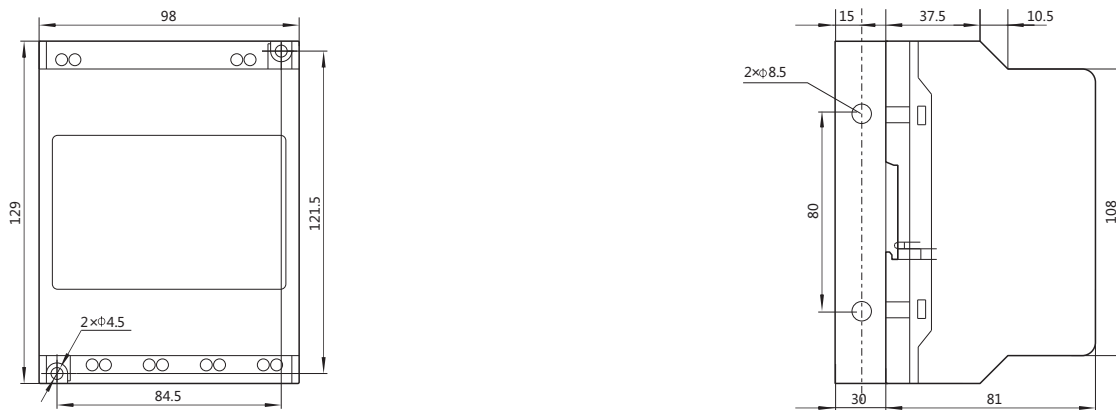

Secondary circuit wiring

1600A frame

M/A type control unit

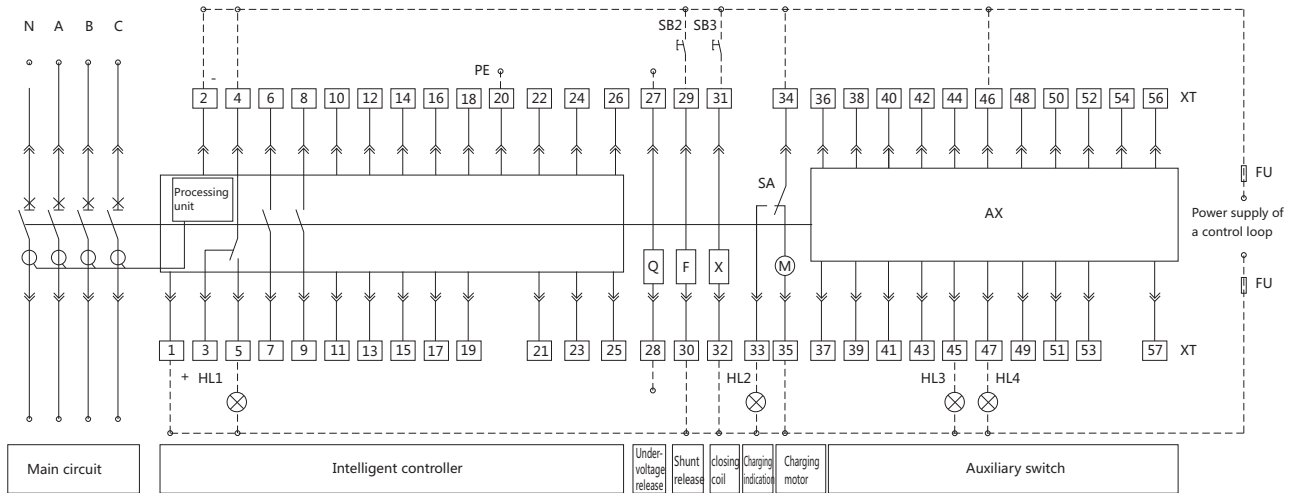

AX auxiliary contact type

For user

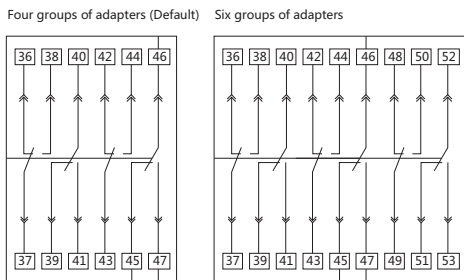

- Q-Undervoltage release F-Shunt release X-Closing coil
- M-Charging motor SA-Limited XT-Wiring terminal
- AX-Auxiliary contact SB1-Emergency stop button
- SB2-Tripping push button SB3-Closing push button HL1-Failure indication lamp
- HL2-Charging indication lamp HL3-Tripping indication lamp
- HL4-Closing indication lamp FU-Fuse (6A)
- 1#, 2#: Power supply of intelligent controller
- 3#~5#: Tripping alarm contact (4-common point)
- 6#, 9#: Auxiliary contact, normally open contact
- 10#~11#: Empty
- 12#~19#: Empty
- 20#: PE line
- 21#~24#: Empty

- 25#~26#: External N-phase transformer input signal contacts. Conventional products are empty. When an external transformer is required to be attached for special order of users, they are external transformer signal input contacts.
- 27#, 28#: Undervoltage release (Connected to the main circuit)
- 29#, 30#: Shunt release
- 31#, 32#: Closing coil
- 33#, 34#: Charging indication
- 34#, 35#: Charging motor
- 36#~56#: Auxiliary contact
- Conventional products are four groups of adapters, and six groups of adapters can be provided(only for AC) for special order for users.
- Note: The full line section is connected, and the dot line is connected by customers.

1600A frame

P/H type control unit

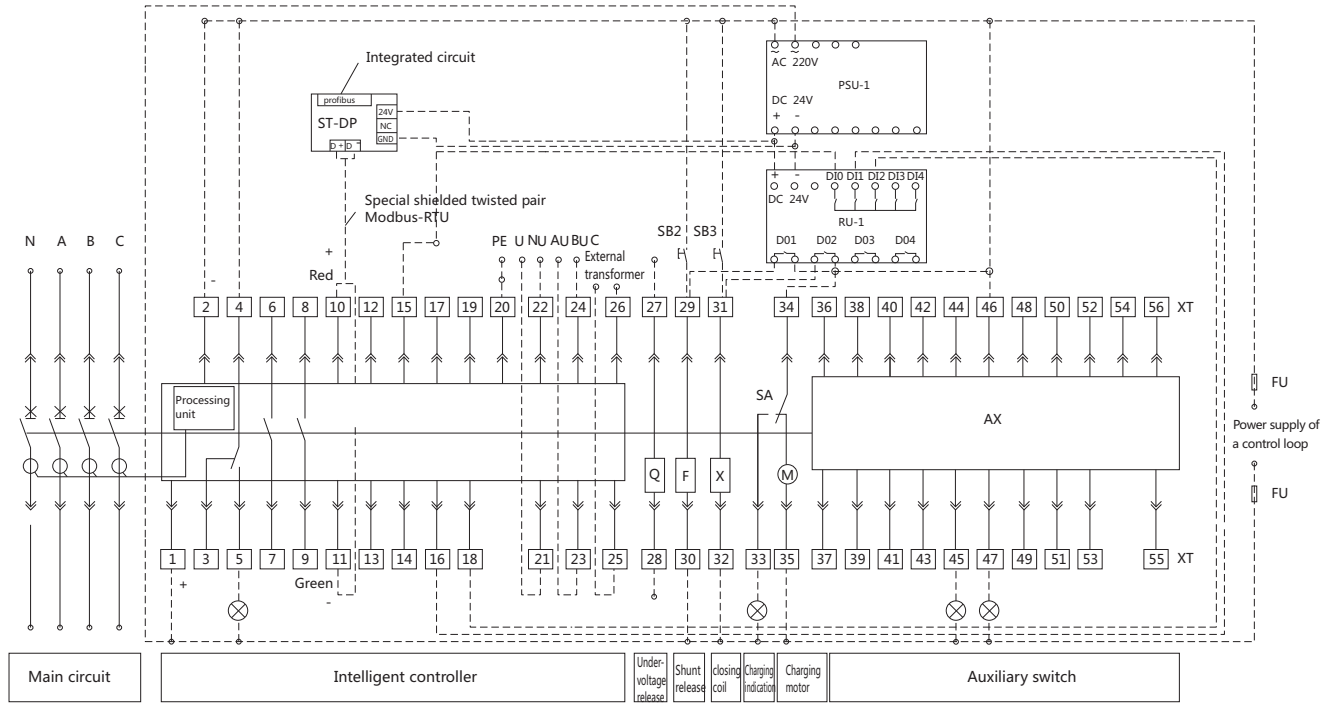

AX auxiliary contact type

For user

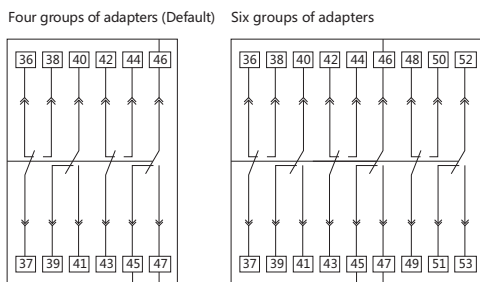

- Q-Undervoltage release F-Shunt release
- X-Closing coil M-Charging motor
- SA-Limited switch XT-Wiring terminal AX-Auxiliary contact
- SB1-Emergency stop button SB2-Tripping push button
- SB3-Closing push button HL1-Failure indication lamp
- HL2-Charging indication lamp
- HL3-Tripping indication lamp HL4-Closing indication lamp
- FU-Fuse (6A) PSU-1—power module
- 1#, 2#: Power supply of intelligent controller
- 3#~5#: Tripping alarm contact (4-common point)
- 6#~9#: Auxiliary contact, normally open contact
- 10#~11#: Defaulted communication output contact for a H type intelligent controller. P type is empty
- 12#~19#: Four groups of programmable output contacts
- 12# : com, 18#D01, 16#D02, 14#D03, 13#D04

H type intelligent controller with a programmable output contact outputs in default: 12#, 13#: load 1 alarm, 12#, 14#: load 2 alarm, 12#,16#: tripping signal output, 12#, 18#: Closing signal output

P type intelligent controller with a programmable output contact outputs in default: 12#, 13#: load 1 alarm, 12#, 14#: load C alarm, 12#, 16#: self-diagnosis alarm, 12#, 18#: failure tripping.

20#: PE line.

21#~24#: voltage display input signal contact

P/H type intelligent controller 21#:N-phase voltage signal

22#: A-phase voltage signal 23#:B-phase voltage signal, 24#: C- phase voltage signal

25#~26#: External N-phase transformer or external earth current transformer input signal contacts. Conventional products are empty. When an external transformer is required for special order for users, they are external transformer signal input contacts.

27#, 28#: Undervoltage release (Connected to the main circuit)

29#, 30#: Shunt release

31#, 32#: Closing coil

33#, 34#: Charging indication

34#, 35#: Charging motor

36#~56#: Auxiliary contact

Conventional products are four groups of adapters, and six groups of adapters can be provided for special order for users (only for AC).

ST-DP: DP protocol module. When the upper computer communication protocol is Modbus-RTU, the ST-DP protocol module is not required. When the upper computer communication protocol is Profibus-DP, the Modbus-RTU protocol module is required to be converted into Profibus-DP protocol by the ST-DP protocol module, extra fee needed.

RU-1: relay module. The circuit breaker is used for tripping and switching via remote control, and is used for tripping and switching signal energy amplification, extra fee needed.

Note: The full line section is connected, and the dot line should be connected by customers.

2000-6300A frame

M/A type control unit

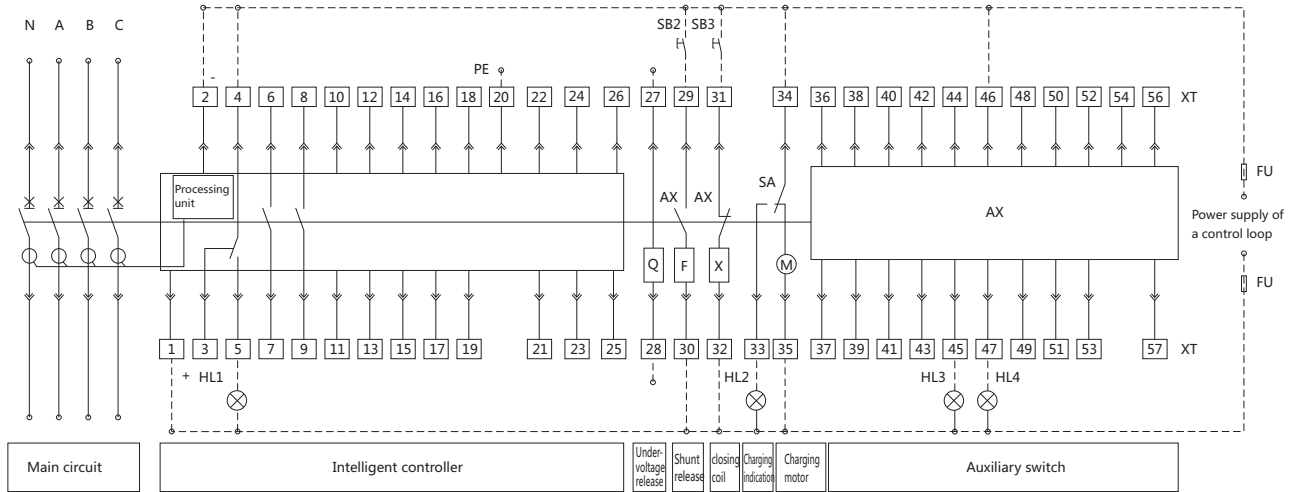

AX auxiliary contact type

For user

Four groups of adapters (Default)

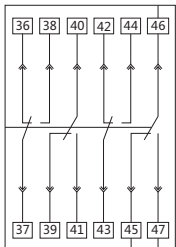

Five groups of adapters

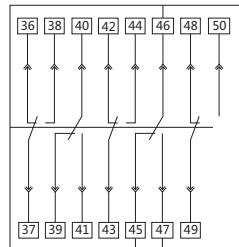

Three-open three-closed auxiliary contact

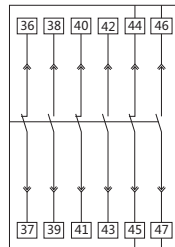

Four-open four-closed auxiliary contact

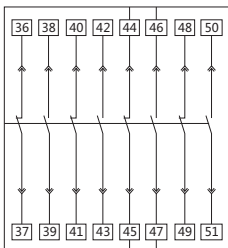

Five-open five-closed auxiliary contact

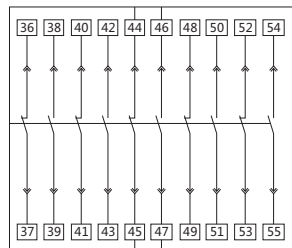

Six-open Six-closed auxiliary contact

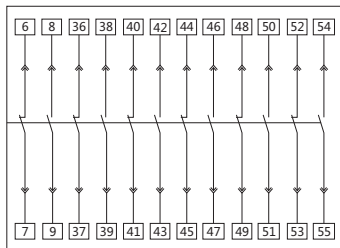

- Q-Undervoltage release F-Shunt release X-Closing coil
 - M-Charging motor SA-Limited switch XT-Wiring terminal
 - AX-Auxiliary contact SB1-Emergency stop button SB2-Tripping push button
 - SB3-Closing push button HL1-Failure indication lamp
 - HL2-Charging indication lamp HL3-Tripping indication lamp
 - HL4-Closing indication lamp FU-Fuse (6A)
 - 1#, 2#: Power supply of intelligent controller
 - 3#~5#: Tripping alarm contact (4-common point)
 - 6#~9#: Auxiliary contact, normally open contact
 - 10#~11#: Empty
 - 12#~19#: Empty
 - 20#: PE line
 - 21#~24#: Empty
 - 25#~26#: External N-phase input signal contacts.
- Conventional products are empty. When an external transformer is required to be attached for special order of users, they are external transformer signal input contacts.
- 27#, 28#: Undervoltage release (Connected to the main circuit or connected to the output of the undervoltage delay module)
 - 29#, 30#: Shunt release
 - 31#, 32#: Closing coil
 - 33#, 34#: Charging indication
 - 34#, 35#: Charging motor
 - 36#~56#: Auxiliary contact
- Conventional products are four groups of adapters. The three-open three-closed auxiliary contact, the four-open four-closed auxiliary contact, the five-open five-closed auxiliary contact, and five groups of adapters can be provided for the special order for users.
- Note: 1. the full line section is connected, and the dot line should be connected by customers.
- Note: 2. when the voltages of the controller of the 2000-4000 frame are AC 230V/AC 400V, the controller can be directly connected to 1#, 2#terminals. When the voltage is DC 220V/DC 110V, the controller can be connected to 1#, 2# terminals after the power supply module outputs DC 24V.

2000-6300A frame

P/H type control unit

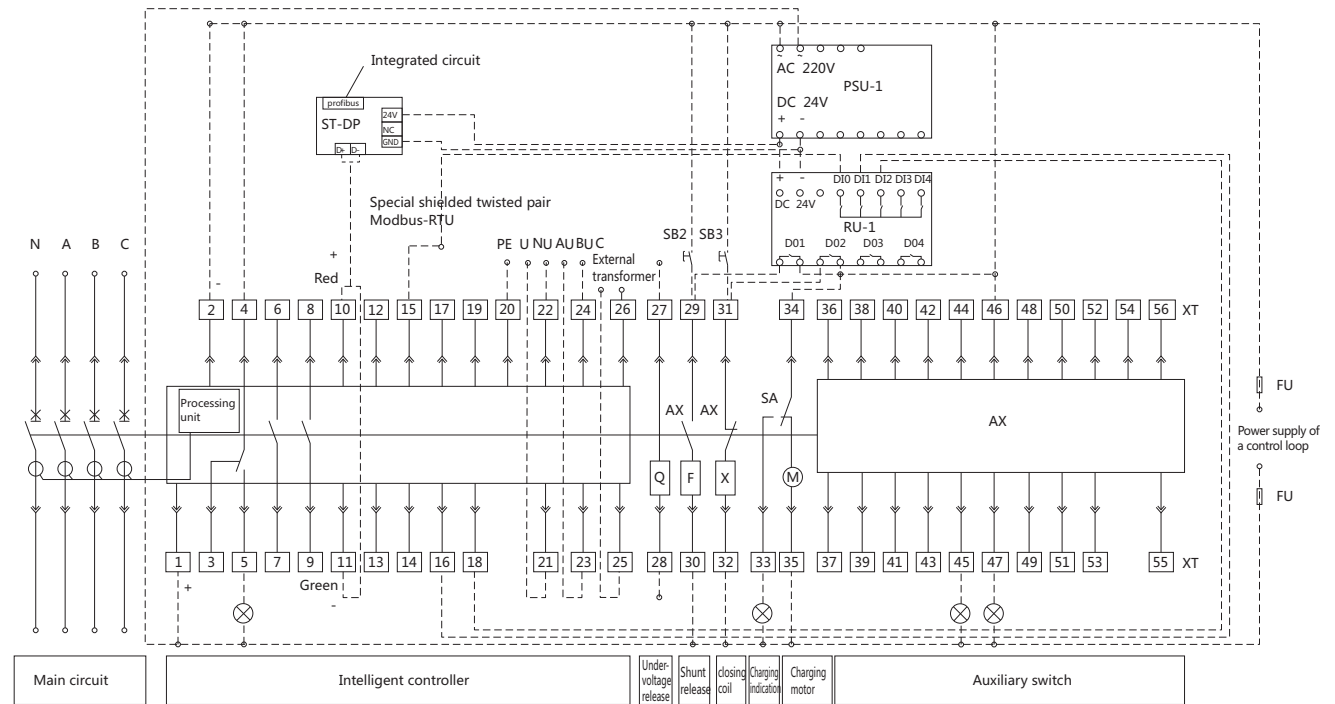

AX auxiliary contact type

For user

Four groups of adapters (Default)

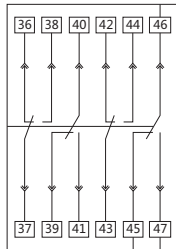

Five groups of adapters

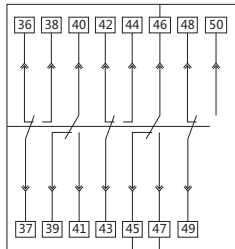

Three-open three-closed auxiliary contact

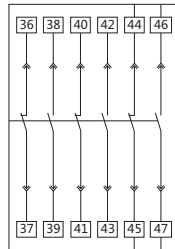

Four-open four-closed auxiliary contact

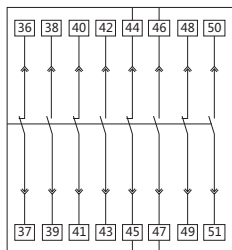

Five-open five-closed auxiliary contact

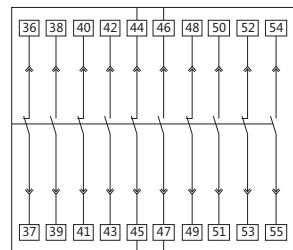

- Q-Undervoltage release F-Shunt release X-Closing coil
- M-Charging motor SA-Limited switch XT-Wiring terminal
- AX-Auxiliary contact SB1-Emergency stop button SB2-Tripping push button
- SB3-Closing push button HL1-Failure indication lamp
- HL2-Charging indication lamp HL3-Tripping indication lamp
- HL4-Closing indication lamp FU-Fuse (6A) PSU-1—power module
- 1#, 2#: Power supply of intelligent controller
- 3#~5#: Tripping alarm contact (4-common point)
- 6#~9#: Auxiliary contact, normally open contact
- 10#~11#: Defaulted communication output contact for a H type intelligent controller.
- P type is empty
- 12#~19#: Four groups of programmable output contacts
- 12# : com, 18 #:D01,16 #:D02,14 #D03,13 #D04
- H type intelligent controller with a programmable output contact outputs in default:
- 12#, 13#: load 1 alarm, 12#, 14#: load 2 alarm, 12#,16#: tripping signal output,
- 12#, 18#: switching signal output.
- P type intelligent controller with a programmable output contact outputs in default:
- 12#, 13#: load 1 alarm, 12#, 14#: load C alarm, 12#,16#: self-diagnosis alarm,
- 12#, 18#: failure tripping.
- 20#: PE line.

21#~24#: voltage display input signal contact

P/H type intelligent controller

21#: N-phase voltage signal, 22#: A-phase voltage signal

23#: B-phase voltage signal, 24#: C-phase voltage signal

25#~26#: External N-phase transformer or external earthing current transformer input signal contacts.

Conventional products are empty. When an external transformer is required for special order for users, they are external transformer signal input contacts.

27#, 28#: Undervoltage release (Connected to the main circuit or connected to the output of the undervoltage delay module)

29#, 30#: Shunt release, 31#, 32#: Closing coil, 33#, 34#: Charging indication

34#, 35#: Charging motor, 36#~56#: Auxiliary contact

Conventional products are four groups of adapters. The three-open three-closed auxiliary contact, the four-open four-closed auxiliary contact, the five-open five-closed auxiliary contact, and five groups of adapters can be provided for the special order for users.

ST-DP: DP protocol module. When the upper computer communication protocol is Modbus-RTU, the ST-DP protocol module is not required. When the upper computer communication protocol is Profibus-DP, the Modbus-RTU protocol module is required to be converted into Profibus-DP protocol by the ST-DP protocol module, extra fee needed.

RU-1: relay module. The circuit breaker is used for breaking and making via remote control, and is used for breaking and making signal energy amplification, extra fee needed.

Note: 1. the full line section is connected, and the dot line should be connected by customers.

Note: 2. when the voltages of the controller of the 2000-4000 frame are AC 230V/AC 400V, the controller can be directly connected to 1#, 2#terminals.

When the voltage is DC 220V/DC 110V, the controller can be connected to 1#, 2# terminals after the power supply module outputs DC 24V.

Chassis position indicator device

Wiring diagram

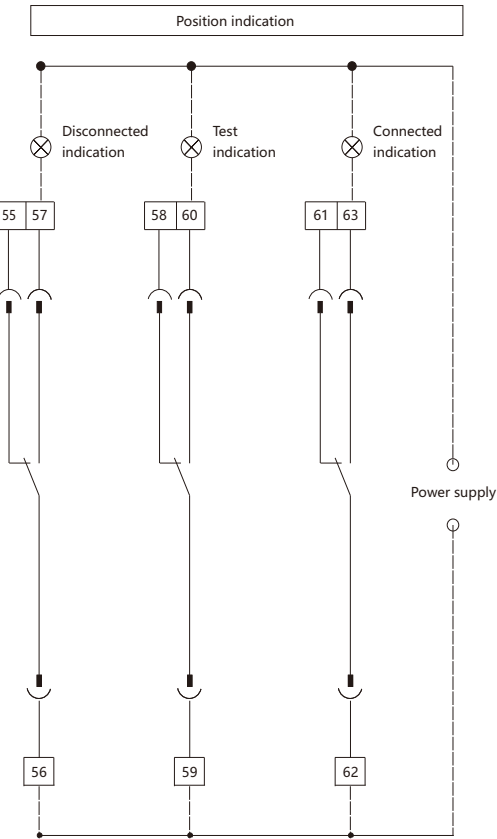

Operation requirements:

1. The chassis indication device can indicate the positions including "disconnected", "test" and "connected" which are completely or partially used according to the requirements of order.
2. When the body of the draw-out type circuit breaker is pushed from the "disconnected" position to the "test" position, 55# and 56# terminals should be transferred from connection into disconnection, and 56# and 57# terminals should be transferred from disconnection to connection.
3. When the body of the draw-out type circuit breaker is pushed from the "disconnected" position to the "test" position, 58# and 59# terminals should be transferred from connection into disconnection, and 59# and 60# terminals should be transferred from disconnection to connection. There is sufficient safety distance between the bus of the circuit breaker body and a bridge-type contact of the safety shutter, and tripping and switching operation can be carried out reliably.
4. When the body of the draw-out type circuit breaker is switched from the "test" position to the "connected" position, NXA16 type secondary circuit has no clearance. The NXA20-63 type safety shutter swing continuously after sending out the "cracking" sound, and the safety shutter jiggle handle rotates within 1.5 circles. 61# and 62# terminals are being transferred from connection to disconnection. 62# and 63# terminals are transferred from disconnection to connection. The busbar of circuit breaker body is required to be reliably inserted into the bridge-type contact of the chassis base, and reliably bear the main circuit current to operate.
5. When the body of the draw-out type circuit breaker is pushed from the "connected" position to the "test" position, 58# and 59# terminals should be transferred from connection into disconnection, and 59# and 60# terminals should be transferred from disconnection to connection. There is sufficient safety distance between the busbar of the circuit breaker body and a bridge-type contact of the chassis, and tripping and switching operation can be carried out reliably.
6. When the body of the draw-out type circuit breaker swings from the "test" position to the "disconnected" position, 55# and 56# terminals should be transferred from connection to disconnection, and 56# and 57# terminals should be transferred from disconnection to connection, and at the same time, the circuit breaker body still cannot be drawn out, and needs to swing toward the "disconnected" position until the handle cannot swing any more, and meanwhile, the circuit breaker body can be drawn out. After the circuit breaker is pulled out, 55# and 56# terminals should be transferred from disconnection to connection, and 56# and 57# terminals should be transferred from connection to disconnection.
7. In the position transfer operation process of the chassis, the operation can only be stopped when the indicator points to "disconnected", "test" and "connected" or the position indicator cannot display the position of the circuit breaker body in the chassis correctly.
8. The above terminal numbers are all position signal specific numbers (55#-63#), which are not compatible with secondary circuit terminal numbers.

Position signal contact capacity

Rated voltage (V)	Rated heating current I _{th} (A)	Rated operating current I _e (A)	Rated control capacity
Ac230	5	1.3	300VA
Ac400	5	0.75	300VA

Frame size	1600A			2000A			3200A			4000A			6300A
Circuit breaker	N <input type="checkbox"/>	S <input type="checkbox"/>	H <input type="checkbox"/>	N <input type="checkbox"/>	S <input type="checkbox"/>	H <input type="checkbox"/>	N <input type="checkbox"/>	S <input type="checkbox"/>	H <input type="checkbox"/>	N <input type="checkbox"/>	S <input type="checkbox"/>	H <input type="checkbox"/>	H <input type="checkbox"/>
Rated current	400A <input type="checkbox"/>			630A <input type="checkbox"/>			1600A <input type="checkbox"/>			3200A <input type="checkbox"/>			4000A <input type="checkbox"/>
	630A <input type="checkbox"/>			800A <input type="checkbox"/>			2000A <input type="checkbox"/>			3600A <input type="checkbox"/>			5000A <input type="checkbox"/>
	800A <input type="checkbox"/>			1000A <input type="checkbox"/>			2500A <input type="checkbox"/>			4000A <input type="checkbox"/>			6300A <input type="checkbox"/>
	1000A <input type="checkbox"/>			1250A <input type="checkbox"/>			3200A <input type="checkbox"/>						
	1250A <input type="checkbox"/>			1600A <input type="checkbox"/>									
Number of poles	3 pole <input type="checkbox"/>			4 pole <input type="checkbox"/> (While In=6300A, no four poles)									
Installation modes	Horizontal draw-out <input type="checkbox"/>						Fixed and horizontal <input type="checkbox"/>						
Intelligent controller	M type <input type="checkbox"/>			A type <input type="checkbox"/>			P type <input type="checkbox"/>			H type <input type="checkbox"/>			
	AC110V <input type="checkbox"/>			AC220/230/240V <input type="checkbox"/>			AC 380/400/415V <input type="checkbox"/>			DC110V <input type="checkbox"/>			DC220V <input type="checkbox"/>
Electric accessories (no AC110V for NXA16)	Under-voltage release (no DC)(Optional)			AC110V <input type="checkbox"/>			AC220/230/240V <input type="checkbox"/>			AC 380/400/415V <input type="checkbox"/>			Order_____V <input type="checkbox"/>
				helped&instantaneous <input type="checkbox"/> helped&delay (Inm≥2000A ,delay time:1s,3s,5s, non-adjustable). <input type="checkbox"/>									
				self-priming&instantaneous <input type="checkbox"/> self-priming&delay (Inm≥2000A,delay time:0.3~7.5s, adjustable) <input type="checkbox"/>									
	Note:NXA16 don't have helped type, delay time:1s,3s,5s,7s, non-adjustable. <input type="checkbox"/>												
shunt release (default in motor operation)	Intermittent (only for Inm≥2000A, by default in motor operation) <input type="checkbox"/>			AC 110V <input type="checkbox"/>			AC220/230/240V <input type="checkbox"/>			AC380/400/415V <input type="checkbox"/>			
				DC110V <input type="checkbox"/>			DC220V <input type="checkbox"/>						
closed electromagnet (default in motor operation)	pulse (must select pulse type in the automatic control system) <input type="checkbox"/>			AC110V <input type="checkbox"/>			AC220/230/240V <input type="checkbox"/>			AC380/400/415V <input type="checkbox"/>			
DC110V <input type="checkbox"/>				DC220V <input type="checkbox"/>									
Motor	AC110V <input type="checkbox"/>			AC220/230/240V <input type="checkbox"/>			AC380/400/415V <input type="checkbox"/>			DC110V <input type="checkbox"/>			DC220V <input type="checkbox"/>
Auxiliary contact	NXA16: C04 <input type="checkbox"/> C06 <input type="checkbox"/> (C06 only for AC) NXA20~63: N3 <input type="checkbox"/> N4 <input type="checkbox"/> N5 <input type="checkbox"/> C03 <input type="checkbox"/> C04 <input type="checkbox"/> C05 <input type="checkbox"/>												
Connection accessories	Interphase barrise <input type="checkbox"/>												
Controller accessories (Match)	External transformer: Earth current transformer <input type="checkbox"/>						External transformer (Neutral CT) <input type="checkbox"/>						
	Note: ¹⁾ Neutral CT is only applicable to 3P+N ²⁾ The earth current transformer should be selected when customers select earth current return type earthing protection.												
Lock mechanism (Match)	Pushbutton lock <input type="checkbox"/>			Safety shutters padlock <input type="checkbox"/>			Body lock <input type="checkbox"/>			One-lock one-key <input type="checkbox"/>			Two-locks one-key <input type="checkbox"/>
	Three-locks two-keys <input type="checkbox"/>			"Disconnected" position padlock <input type="checkbox"/>			Door interlock (Body) <input type="checkbox"/>			Door interlock (chassis) <input type="checkbox"/>			
Mechanical interlock (Match)	MI-3(2on+1off) <input type="checkbox"/>			MI-4 (1on+2off) <input type="checkbox"/>			ILK2 <input type="checkbox"/>						
Source-changeover controller (Match)	1 "Normal" and 1 "Replacement" <input type="checkbox"/> 2 "Incoming" and 1 "Busbar" <input type="checkbox"/>												



Earth protection

There are two protected modes for metal single-phase earth fault, namely vector sum(T) and earth current(W).Type-T detects zero sequence current and four-phase current vector(three-phase four-wire system) or three-phase current vector(three-phase three-wire system) will be added to provide reference for earth protection. Type-W detects earthing cable current directly by special external transformer. Type-W can protect both stages of breaker at the same time. Distance between the transformer and breaker should be no more than 5m. Zone interlocking can be used in the condition of vector sum earth fault.

a.correlation setting parameters of earth protection

Parameter Names	Setting range	Setting step size	Remarks
Set value of action current I _g	OFF+(0.2~1.0)×In (Frame NXA16/NXA20, Max= 1200A) OFF+(500A~1200A) (Frame NXA32/NXA40/NXA63)	1A	
delay time T _g	(0.1~0.4)S	0.1s	
Zone interlocking of earth fault (for T-type earth fault) (ZSI)	1.At least one way of DO should be set as "Zone Interlocking" or "earth Interlocking" 2.At least one way of DI should be set as "Zone Interlocking" or "earth Interlocking"		Signal unit options must be S2 or S3 When DI/DO is set as zone interlocking , it effects "Earth Zone Interlocking" and "Short Zone Interlocking" When DI/DO is set as earth interlocking, it only effects "earth Zone Interlocking". If the function isn't set, it has no effect.

b. Operating characteristic of earth protection

Characteristic	I/I _g	Tripping time	Permissible error
Non-operating characteristic	< 0.9	Non-operate	
Operation characteristic	> 1.1	Operate	
Time-delay operation	≥1.1	Note	±15% or inherent absolute error±40ms(choose the max value)

Note: The delay time of earth fault is divided into two stages, inverse time and definite time. When fault current is less than 1.0In or 1200A,the protection is inverse, the time delay is calculated as follow:
 $t=(1.0In \text{ or } 1200A/I)^2 \times T_g$
 In this equation: t---action time
 T_g --- setting delay time
 I---fault earth current



When fault current is more than $1.0I_n$ or 1200A, the protection is definite; the time delay is the setting delay time.

c. Schematic Diagram of detection

Type-T

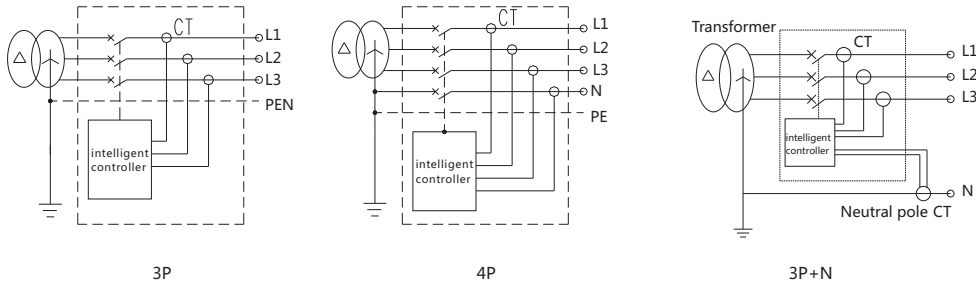

Type-W

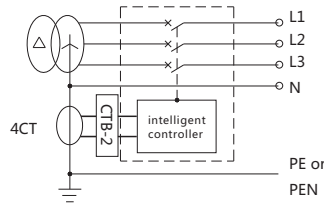

4CT:external special transformer CTB-2:earth current transformer module

Leakage protection (E)

Leakage protection applies to leakage fault caused by insulation failure of equipment or human touching exposed electric conduction position. Leakage tripping current $I_{\Delta n}$ is independent of breaker rated current. An extra rectangular transformer is needed for zero sequence sampling method. This method is appropriate for small current protection because of its high accuracy and sensitivity.

a. correlation setting parameters of leakage protection

Parameter Names	Setting range	Setting step size
Set value of action current $I_{\Delta n}$	(0.5~30.0)A	0.1A
Delay time $T_{\Delta n}(S)$	Instantaneous , 0.06 , 0.08 , 0.17 , 0.25 , 0.33 , 0.42 , 0.5 , 0.58 , 0.67 , 0.75 , 0.83	
Operation mode	Trip/Turn off	

b. Operating characteristic of leakage protection

Characteristic	$I/I_{\Delta n}$	Tripping time	Permissible error
Non-operating characteristic	< 0.8	Non-operate	
Operation characteristic	> 1.0	Operate	
Time-delay operation	≥ 1.0	Shown in Table 18	$\pm 10\%$ (inherent absolute error $\pm 40ms$)

Setting time(s)	0.06	0.08	0.17	0.25	0.33	0.42	0.5	0.58	0.67	0.75	0.83	Instantaneous
Multiple of Fault Current	Maximum Breaking Time(s)											
1 $I_{\Delta n}$	0.36	0.5	1	1.5	2	2.5	3	3.5	4	4.5	5	0.04
2 $I_{\Delta n}$	0.18	0.25	0.5	0.75	1	1.25	1.5	1.75	2	2.25	2.5	0.04
5 $I_{\Delta n}$	0.072	0.1	0.2	0.3	0.4	0.5	0.6	0.7	0.8	0.9	1	0.04
10 $I_{\Delta n}$												

c. Schematic Diagram of leakage protection

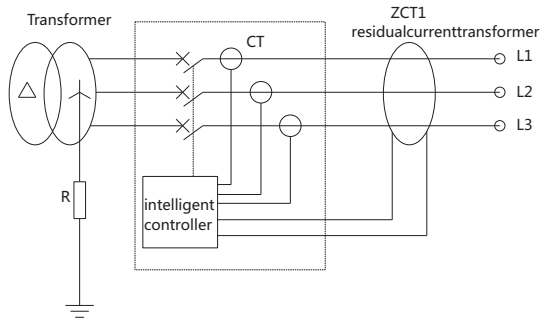

ZCT1:rectangular leakage transformer (NXA16&NXA20-3P)

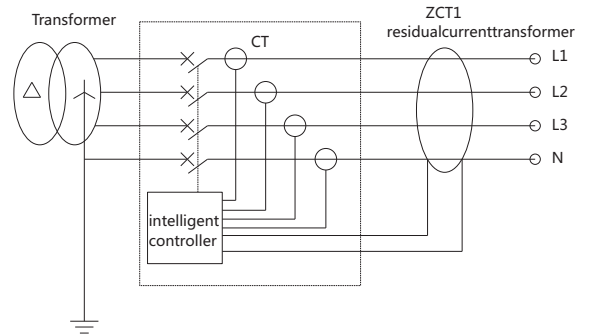

ZCT1 : rectangular leakage transformer(NXA16-4P)

Note: For Frame nxa16(3P&4P) and NXA20(3P) products, busbar can go through ZCT1, however, not for Frame NXA20 4P and FrameNXA32/NXA40/NXA63.

Dual earth fault protection

NXA P/H type controller has a unique feature: the installation of two independent earth fault protection curves is permissible, so that two kinds of configurations can be managed at the same time. The release can differentiate unlimited regional earth faults because of the feature to command the NXA circuit breaker to trip and the limited regional earth fault to command the medium-voltage circuit breaker to strip.

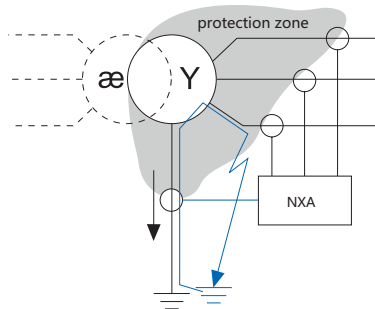

Functions of the controller

2A type display and operation

CD-1: A 2A type source-changeover system is used for the switch between power grids or between the power grid and generator. When a normal power supply does not supply power normally, such as undervoltage, overvoltage, phase breaking, a spare power supply is switched for supplying power. A mechanical interlock component is configured according to standard.

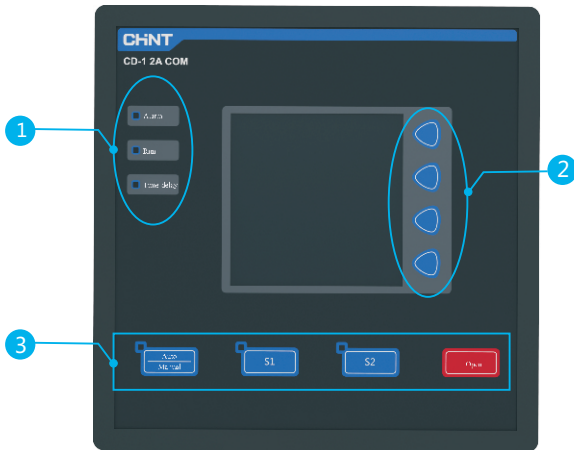

Switch operation zone	Automatic (The system judges the operation automatically, and the light is on when pressing the left upper part)
	Manual (The mechanism is operated by a handle or with buttons S1, S2 and OFF operation)
	S1: load is powered by switching to S1, and the light is on when pressing S1 in the left upper part.
	S2: load is powered by switching to S2, and the light is on when pressing S2 in the left upper part.
	Disconnection: S1, S2 are stripped, and the system load is not powered
	Pressing anyone of buttons S1, S2 and OFF under the automatic condition, the system becomes manual, and corresponding operation is carried out when pressing corresponding buttons.

2A type of functions

The controller has the following functions

1. Dual-circuit voltage detection display
2. Overvoltage threshold value adjustment: 400V-480V
3. Undervoltage threshold value adjustment: 280V-360V
4. Adjustment of T1, T2, T3 and T4: 0.5-64S with the step size of 0.5S
5. Undervoltage and overvoltage fault indication
6. Power supply fault indication
7. State indication of the circuit breaker
8. Self-input and self-reset or self-input and self-reset selection
9. Manual or automatic selection
10. Comprehensive alarm for transfer failure (fault of the circuit breaker, sending fault of control signals and unmet transfer conditions)
11. All primary adjustment states after resetting and before defaulting
12. Alarm contact
13. Unloading contact
14. Startup contact of a power generator
15. Standard configuration
16. Mechanical interlock
17. The controller has an overvoltage protection function, and operates normally with long-term overvoltage: 130% Ue.

Truth table

S1-circuit power supply	S2-circuit power supply
1	0
0	0
0	1

3A type display and operation

CD-1 A 3A source-changeover system is applicable to a power supplying system with two power supplies and one buscouple. In the manual operation process, load cannot lead to power interruption, so that the safety running level and the power supplying continuity for power distribution are enhanced. The 3A automatic power supply conversion system is applied to electric places.

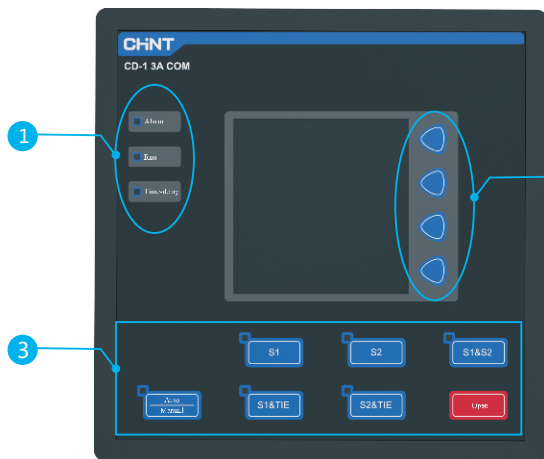

Automatic (The system judges the operation automatically, and the light is on when pressing the left upper part)
Manual (The mechanism is operated by a handle or with buttons S1, S2, S1 & S2, S1&TIE, S2&TIE and OFF operation)
S1: load is powered by switching to S1, the TIE buscouple is tripped, and the light is on at the left upper part when pressing S1.
S2: load is powered by switching to S2, the TIE buscouple is tripped, and the light is on at the left upper part when pressing S2.
S1 & S2: Load is powered by S1 & S2, TIE buscouple is tripped; the light is on at the left upper part when pressing S1 & S2.
S1&TIE: Load is powered by S1, TIE buscouple is tripped; the light is on at the left upper part when pressing S1&TIE
S2&TIE: Load is powered by S2, TIE buscouple is tripped; the light is on at the left upper part when pressing S2&TIE
Disconnection: S1,S2 and TIE are all tripped, and the system load is not powered.
Pressing anyone of buttons S1, S2 S1 & S2, S1&TIE, S2&TIE under the automatic condition, the system becomes manual, and corresponding operation is carried out when pressing corresponding buttons.

3A type functions

The controller has the following functions

1. Dual-circuit voltage detection display
2. Overvoltage threshold value adjustment: 400V-480V
3. Undervoltage threshold value adjustment: 280V-360V
4. Adjustment of T1, T2, T3 and T4: 0.5-64S with the step size of 0.5S
5. Undervoltage and overvoltage fault indication
6. Power supply fault indication
7. State indication of the circuit breaker
8. Self-input and self-reset or self-input and self-reset selection
9. Manual or automatic selection
10. Comprehensive alarm for transfer failure (fault of the circuit breaker, sending fault of control signals and unmet transfer conditions)
11. All primary adjustment states after resetting and before defaulting
12. Alarm contact
13. Unloading function
14. Standard configuration
15. Mechanical interlock
16. The controller has an overvoltage protection function, and operates normally with long-term overvoltage: 130% Ue.

Truth table

S1-circuit power supply	TIE buscouple	S2-circuit power supply
1	0	1
1	1	0
0	1	1
1	0	0
0	0	1
0	0	0

